

Service  
Service  
**Service**



# Service Manual



## TABLE OF CONTENTS

	Chapter
Location of PCB Boards .....	1-2
Versions Variation .....	1-2
Specifications .....	1-3
Measurement Setup .....	1-4
Service Aids .....	1-5
ESD & Safety Instruction .....	1-6
Lead-free soldering Information .....	1-7
Setting procedure & Repair Instructions.....	2
Disassembly Instructions & Service positions .....	3
Quick Start Guide .....	4
Block & Wiring Diagram .....	5
VFD+USB Board .....	6
Main Board .....	7
Power Board .....	8
Mechanical Exploded view .....	11
Revision List .....	12

© Copyright 2010 Philips Consumer Electronics B.V. Eindhoven, The Netherlands  
All rights reserved. No part of this publication may be reproduced, stored in a retrieval system or transmitted, in any form or by any means, electronic, mechanical, photocopying, or otherwise without the prior permission of Philips.

Published by RY\_LYF\_1130 Service Audio Printed in The Netherlands Subject to modification

GB 3139 785 35561

Version 1.1



# PHILIPS

# LOCATION OF PCB BOARDS

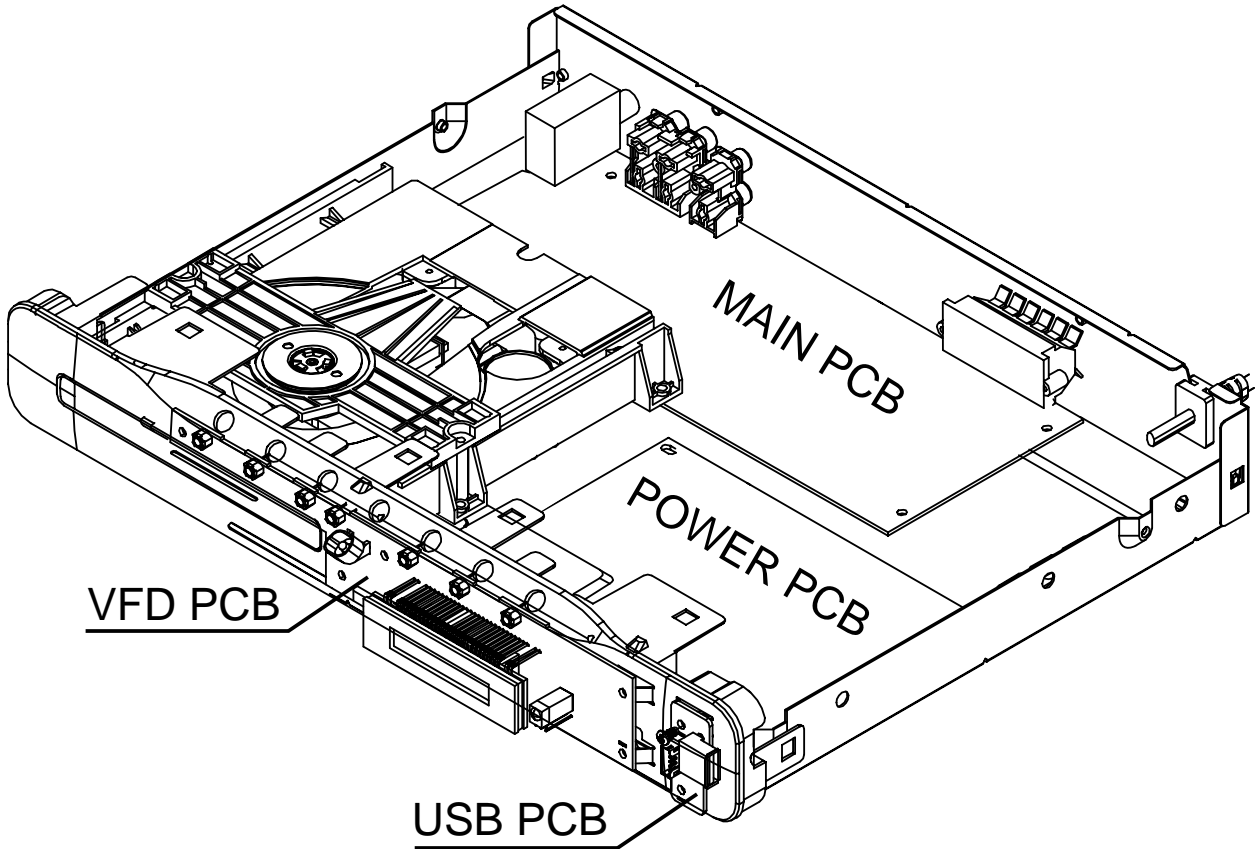

## VERSION VARIATION:

Type/Versions	HTS2501				
Features	/12	/94	/98		
Output Power - 240W		X	X		
Output Power - 300W	X	X	X		
Voltage (110-240V)	X	X	X		
AUX	X	X	X		

## REPAIR SCENARIO MATRIX:

Type/Versions	HTS2501				
Board in used	/12	/94	/98		
Main Board	C	C	C		
Power Board	C	C	C		
VFD+USB Board	C	C	C		

\*C = Component Level Repair

# SPECIFICATIONS

## Playback media

DVD-Video, DVD+R/+RW, DVD-R/-RW, CD-R/CD-RW, Audio CD, Video CD/SVCD, Picture CD, MP3-CD, WMA-CD, DivX-CD, USB storage device

## File Format

Audio ..... .mp3, .wma  
Video ..... .divx, .divx ultra, .mpeg, .mpg, .wmv (simple profile)  
Picture ..... .jpeg, .jpg

## Amplifier

Total output power..... 300 W RMS (30% THD) (for:/12)  
Total output power..... 240 W RMS (10% THD),  
..... 300 W RMS (30% THD) (for:/94/98)  
Frequency response..... 20 Hz-20 kHz /±3dB  
Signal-to-noise ratio..... > 65 dB (CCIR) /(A-weighted)  
Input sensitivity.....  
AUX ..... 1000 mV

## Video

Signal system ..... PAL / NTSC

## Audio

Sampling frequency.....  
MP3 ..... 32 kHz, 44.1 kHz, 48 kHz  
WMA..... 44.1 kHz, 48 kHz  
Constant bit rate .....  
MP3 ..... 112 kbps - 320 kbps  
WMA..... 48 kbps - 192 kbps

## Radio

Tuning range ..... FM 87.5-108 MHz (50 kHz)  
Signal-to-noise ratio..... FM 50 dB  
Frequency response..... FM 180 Hz-10 kHz/ ±6dB

## USB

Compatibility ..... USB  
Class support..... UMS (USB Mass Storage Class)  
File system ..... FAT16, FAT32  
Maximum memory support..... < 160GB

## Main Unit

Power supply ..... 110-240V, ~50-60 Hz;  
Power consumption..... 55 W  
Standby power consumption ..... ≤ 0.9 W  
Dimensions (WxHxD) ..... 360 x 58 x 303(mm)  
Weight ..... 2.3 kg

## Speakers

System..... full range satellite  
Speaker impedance..... 3 ohm  
Speaker drivers ..... 3" full range  
Frequency response..... 150 Hz-20 kHz  
Dimensions (WxHxD) ..... 100 x 100 x 75(mm)  
Weight ..... 0.30-0.66 kg/each  
Cable length .....  
Center..... 1 m  
Front ..... 2 m  
Rear..... 10 m

## Subwoofer

Impedance..... 12 ohm  
Speaker drivers ..... 133 mm (5.25") woofer  
Frequency response..... 40 Hz-150 kHz  
Dimensions (WxHxD) ..... 60 x 267.5 x 265 (mm)  
Weight ..... 2.65 kg  
Cable length ..... 2 m

## Laser specification

Type..... Semiconductor laser GaAlAs (CD)  
Wave length..... 645 - 665 nm (DVD), 770 - 800 nm (CD)  
Output power ..... 6 mW (DVD), 7 mW (VCD/CD)  
Beam divergence..... 60 degrees.

Specifications subject to change without prior notice.

# MEASUREMENT SETUP

## Tuner FM

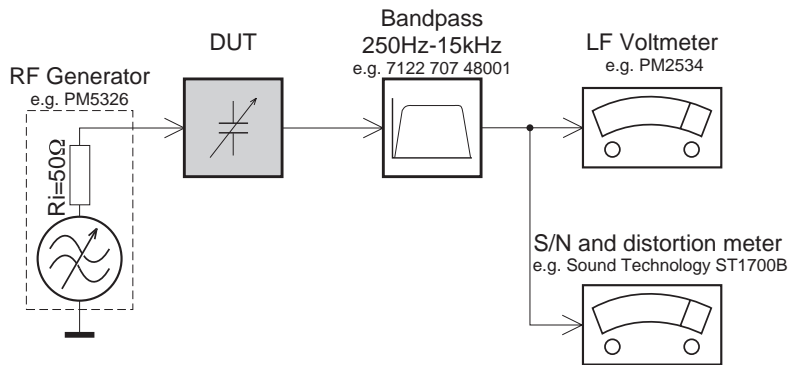

Use a bandpass filter to eliminate hum (50Hz, 100Hz) and disturbance from the pilotone (19kHz, 38kHz).

## CD

Use Audio Signal Disc SBC429 4822 397 30184  
(replaces test disc 3)

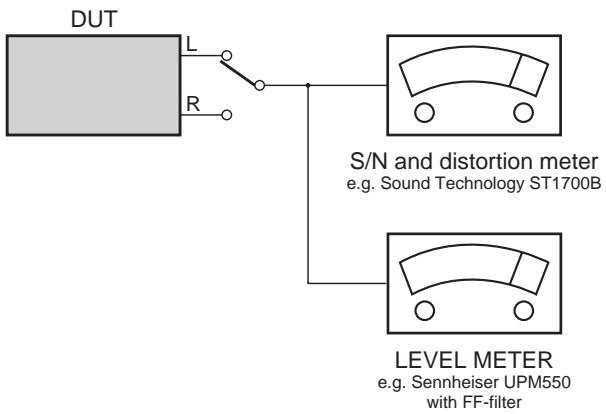

# SERVICE AIDS

## Service Tools:

- Universal Torx driver holder .....4822 395 91019
- Torx bit T10 150mm .....4822 395 50456
- Torx driver set T6-T20 .....4822 395 50145
- Torx driver T10 extended .....4822 395 50423

## Compact Disc:

- SBC426/426A Test disc 5 + 5A .....4822 397 30096
- SBC442 Audio Burn-in test disc 1kHz .....4822 397 30155
- SBC429 Audio Signals disc .....4822 397 30184
- Dolby Pro-logic Test Disc .....4822 395 10216

## HANDLING CHIP COMPONENTS

**GENERAL**

SOLDER    CHIP COMPONENT    SOLDER  
COPPER TRACK    P.C.B.  
GLUE

SERVICE PACKAGE

**DISMOUNTING**

VACUUM PISTON  
4822 395 10082

SOLDERING IRON  
e.g. WELLER solder tip PT-H7

SOLDERING IRON  
SOLDER WICK  
4822 321 40042

e.g. A PAIR OF TWEEZERS

HEATING    HEATING

SOLDERING IRON  
SOLDER WICK    CLEANING

**MOUNTING**

e.g. A PAIR OF TWEEZERS

SOLDER  
ø0.5-0.8mm    PRESSURE

SOLDERING IRON

SOLDERING TIME  
< 3 sec/side

PRESSURE    SOLDER ø0.5-0.8mm    SOLDERING IRON

**PRECAUTIONS**

SOLDERING IRON    CORRECT    SOLDERING IRON

COPPER TRACK

SOLDERING IRON    CHIP COMPONENT

**EXAMPLES**

CORRECT

SOLDERING IRON    NO!

**ESD****(GB) WARNING**

All ICs and many other semi-conductors are susceptible to electrostatic discharges (ESD). Careless handling during repair can reduce life drastically.

When repairing, make sure that you are connected with the same potential as the mass of the set via a wrist wrap with resistance. Keep components and tools also at this potential.

**(F) ATTENTION**

Tous les IC et beaucoup d'autres semi-conducteurs sont sensibles aux décharges statiques (ESD).

Leur longévité pourrait être considérablement écourtée par le fait qu'aucune précaution n'est prise à leur manipulation.

Lors de réparations, s'assurer de bien être relié au même potentiel que la masse de l'appareil et enfiler le bracelet serti d'une résistance de sécurité.

Veiller à ce que les composants ainsi que les outils que l'on utilise soient également à ce potentiel.

**(D) WARNUNG**

Alle ICs und viele andere Halbleiter sind empfindlich gegenüber elektrostatischen Entladungen (ESD).

Unvorsichtige Behandlung im Reparaturfall kann die Lebensdauer drastisch reduzieren. Veranlassen Sie, dass Sie im Reparaturfall über ein Pulsarmband mit Widerstand verbunden sind mit dem gleichen Potential wie die Masse des Gerätes.

Bauteile und Hilfsmittel auch auf dieses gleiche Potential halten.

**(NL) WAARSCHUWING**

Alle IC's en vele andere halfgeleiders zijn gevoelig voor electrostatische ontladingen (ESD).

Onzorgvuldig behandelen tijdens reparatie kan de levensduur drastisch doen verminderen. Zorg ervoor dat u tijdens reparatie via een polsband met weerstand verbonden bent met hetzelfde potentiaal als de massa van het apparaat.

Houd componenten en hulpmiddelen ook op hetzelfde potentiaal.

**(I) AVVERTIMENTO**

Tutti IC e parecchi semi-conduttori sono sensibili alle scariche statiche (ESD).

La loro longevità potrebbe essere fortemente ridotta in caso di non osservazione della più grande cauzione alla loro manipolazione. Durante le riparazioni occorre quindi essere collegato allo stesso potenziale che quello della massa dell'apparecchio tramite un braccialetto a resistenza.

Assicurarsi che i componenti e anche gli utensili con quali si lavora siano anche a questo potenziale.

**(GB) ESD PROTECTION EQUIPMENT**

Complete Kit ESD3 (small tablemat, wristband, connection box, estention cable and earth cable ..... 4822 310 10671  
Wristband tester ..... 4822 344 13999

**(GB)**

Safety regulations require that the set be restored to its original condition and that parts which are identical with those specified, be used.

Safety components are marked by the symbol  $\Delta$ .

**(NL)**

Veiligheidsbepalingen vereisen, dat het apparaat bij reparatie in zijn oorspronkelijke toestand wordt teruggebracht en dat onderdelen, identiek aan de gespecificeerde, worden toegepast.

De Veiligheidsonderdelen zijn aangeduid met het symbol  $\Delta$ .

**(F)**

Les normes de sécurité exigent que l'appareil soit remis à l'état d'origine et que soient utilisés les pièces de rechange identiques à celles spécifiées.

Less composants de sécurité sont marqués  $\Delta$ .

**(D)**

Bei jeder Reparatur sind die geltenden Sicherheitsvorschriften zu beachten. Der Originalzustand des Geräts darf nicht verändert werden; für Reparaturen sind Original-Ersatzteile zu verwenden.

Sicherheitsbauteile sind durch das Symbol  $\Delta$  markiert.

**(I)**

Le norme di sicurezza esigono che l'apparecchio venga rimesso nelle condizioni originali e che siano utilizzati i pezzi di ricambio identici a quelli specificati.

Componenty di sicurezza sono marcati con  $\Delta$ .

**(GB)**

After servicing and before returning set to customer perform a leakage current measurement test from all exposed metal parts to earth ground to assure no shock hazard exist, The leakage current must not exceed 0.5mA.

**(GB) Warning !**

Invisible laser radiation when open.  
Avoid direct exposure to beam.

**(S) Varning !**

Osynlig laserstrålning när apparaten är öppnad och spärren är urkopplad. Betrakta ej strålen.

**(SF) Varoitus !**

Avatussa laitteessa ja suojalukituksen ohitettaessa olet alltiina näkymättömälle laserisäteilylle. Älä katso säteeseen!

**(DK) Advarsel !**

Usynlig laserstrålning ved åbning når sikkerhedsafbrydere er ude af funktion. Undgå udsættelse for stråling.

**(F)**

"Pour votre sécurité, ces documents doivent être utilisés par des spécialistes agréés, seuls habilités à réparer votre appareil en panne".

## Pb(Lead) Free Solder

When soldering, be sure to use the pb free solder.

### IDENTIFICATION:

Regardless of special logo (not always indicated) 

one must treat all sets from **1 Jan 2005** onwards, according next rules:

**Important note:** In fact also products of year 2004 must be treated in this way as long as you avoid mixing solder-alloys (lead-free/ lead-free). So best to always use SAC305 and the higher temperatures belong to this.

Due to lead-free technology some rules have to be respected by the workshop during a repair:

- Use only lead-free solder alloy Philips SAC305 with order code 0622 149 00106. If lead-free solder-paste is required, please contact the manufacturer of your solder-equipment. In general use of solder-paste within workshops should be avoided because paste is not easy to store and to handle.
- Use only adequate solder tools applicable for lead-free solder alloy. The solder tool must be able
  - To reach at least a solder-temperature of 400°C,
  - To stabilize the adjusted temperature at the solder-tip
  - To exchange solder-tips for different applications.
- Adjust your solder tool so that a temperature around 360°C – 380°C is reached and stabilized at the solder joint. Heating-time of the solder-joint should not exceed ~ 4 sec. Avoid temperatures above 400°C otherwise wear-out of tips will rise drastically and flux-fluid will be destroyed. To avoid wear-out of tips switch off unused equipment, or reduce heat.
- Mix of lead-free solder alloy / parts with leaded solder alloy / parts is possible but PHILIPS recommends strongly to avoid mixed solder alloy types (leaded and lead-free).

If one cannot avoid or does not know whether product is lead-free, clean carefully the solder-joint from old solder alloy and re-solder with new solder alloy (SAC305).

- Use only original spare-parts listed in the Service-Manuals. Not listed standard-material (commodities) has to be purchased at external companies.
- Special information for BGA-ICs:
  - Always use the 12nc-recognizable soldering temperature profile of the specific BGA (for de-soldering always use the lead-free temperature profile, in case of doubt)
  - Lead free BGA-ICs will be delivered in so-called 'dry-packaging' (sealed pack including a silica gel pack) to protect the IC against moisture. After opening,

dependent of MSL-level seen on indicator-label in the bag, the BGA-IC possibly still has to be baked dry. (MSL=Moisture Sensitivity Level). This will be communicated via AYS-website.

Do not re-use BGAs at all.

- For sets produced before 1.1.2005 (except products of 2004), containing leaded solder-alloy and components, all needed spare-parts will be available till the end of the service-period. For repair of such sets nothing changes.
- On our website [www.atyourservice.ce.Philips.com](http://www.atyourservice.ce.Philips.com) you find more information to:
  - BGA-de-/soldering (+ baking instructions)
  - Heating-profiles of BGAs and other ICs used in Philips-sets

You will find this and more technical information within the "magazine", chapter "workshop news".

For additional questions please contact your local repair-helpdesk.

## Setting procedure & Repair instruction

### 1) Restore factory setting

- Press <SETUP> button on R/C.
- Select <preference setup> ,then press < OK >.
- Select <default>,then press <OK> to confirm.

### 2) Version control change

- Open the Door,then,press "1" "5" "9" on RC.
- Press <OK> button on RC.
- TV will show message as follow:

Current model:	2501-12/94/98
Version:00.07.02_0	Release:2010.06.10
Region:0	Servo:62.10.00.07
8032: 0F.01.00.09	Risc:01.00.00.04
MCU: 07.00	BootLoader: Er

if current model doesnot match your set,  
use down arrow key on the remote to change

OK

- If current model doesnot match your set, use down arrow key on the remote to change.

### 3) Password change

- Press <SETUP> button on R/C.
- Select <preference setup> ,then press <OK>.
- Select <password> <change>,then press <OK> to confirm  
"0000" is default password supplied.

### 4) Trade model

- Press <Open/Close>button on R/C.
- Press "2" "5" "9" on R/C,VFD will display "TRA ON " or "TRA OFF".

### 5) Check on software version

- Press <SETUP> button on R/C.
- Select <preference setup> ,then press <OK>.
- Select <version info>,then press <OK>.
- TV will show message as follow:

Current model:	2501-12/94/98
Version:00.07.02_0	Release:2010.06.10
Region:0	Servo:62.10.00.07
8032: 0F.01.00.09	Risc:01.00.00.04
MCU: 07.00	BootLoader: Er

OK

Press SETUP to exit menu

### 6) Upgrading new software

- Check for the latest software version on [www.philips.com/support](http://www.philips.com/support).  
Search for your model and click on 'software&drivers'.
- Copy the latest upgrading software onto a CD-R or USB storage device.
- Insert the CD-R program disc or connect the USB storage device to the home theater.
- Press <USB> button on R/C.
- TV will show message as follow:

Upgrade file detected  
Upgrade?  
Press PLAY to start

- Press <PLAY> "▶||" button on R/C.
- TV will show message as follow:

Upgrade file detected  
Upgrade?  
Press PLAY to start  
Upgrading

- When the updated is complete ,the home theater automatically switch to standby.

Note: when upgrade in progress, please do not unplug or switch off the device.

### 7) How to replace the defective DVD Loader

- Remove the defective DVD Loader (see chapter 3).
- Accordingly connect DVD Loader and "CN201", "CN203" on the top of main board as shown below

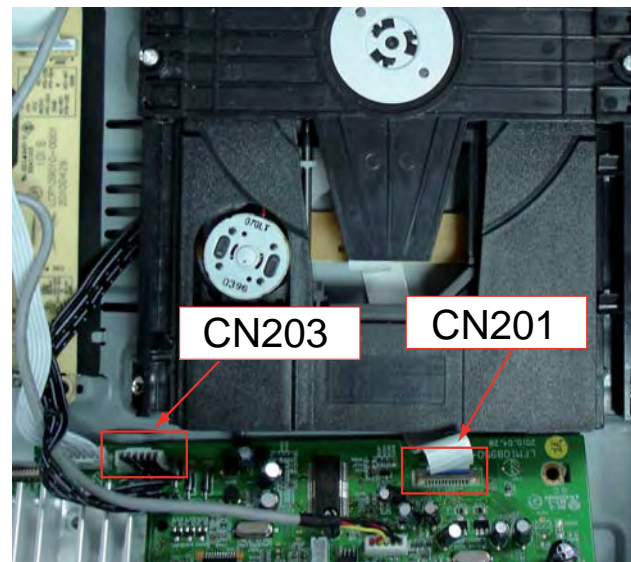

- Remove solder joint on the ESD protection point.

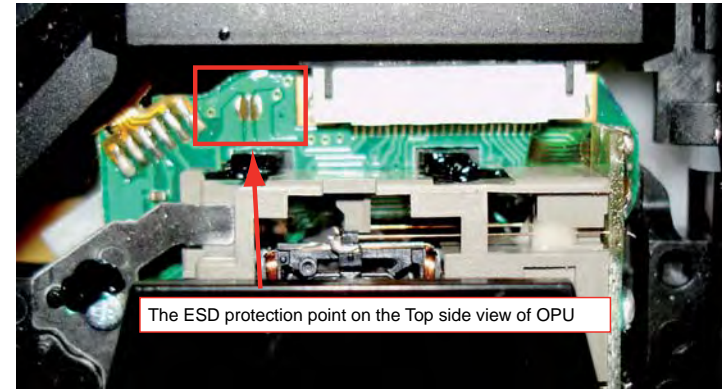

The Top side view of OPU

Note: The ESD protection point on the Top side view of OPU must be soldered if

- the DVD Loader is OK and needs to be disconnected from connector "CN201" and "CN203" of the main board.
- the defective DVD Loader is needed to be send back to supplier for failure analysis and to support back charging evidence.

### 8) Produce to change Tuner grid (only for 198 version)

In some countries, you can switch the FM tuning grid between 50 kHz and 100 kHz. Changing the tuning grid erases all preset radio stations.

- Press<radio> button on R/C
- Press <Stop> button on R/C.
- Press and hold <Play> until (50 kHz) or (100 kHz) is displayed.  
Note: repeaing the same action will toggle back to it previous tuning grid setting.

### CAUTION!

This information is confidential and may not be distributed.Only a qualified service person should reprogram the Region Code.



# MAIN UNIT REPAIR CHART

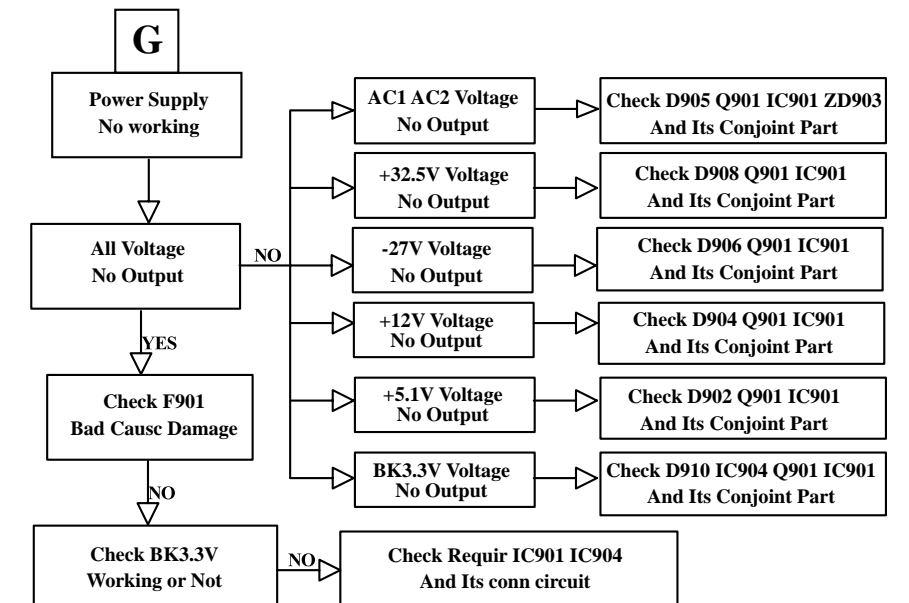
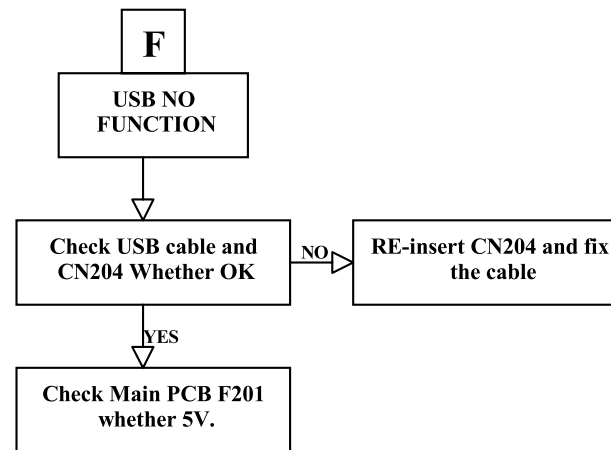
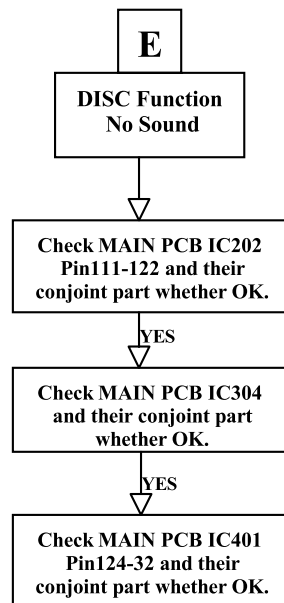
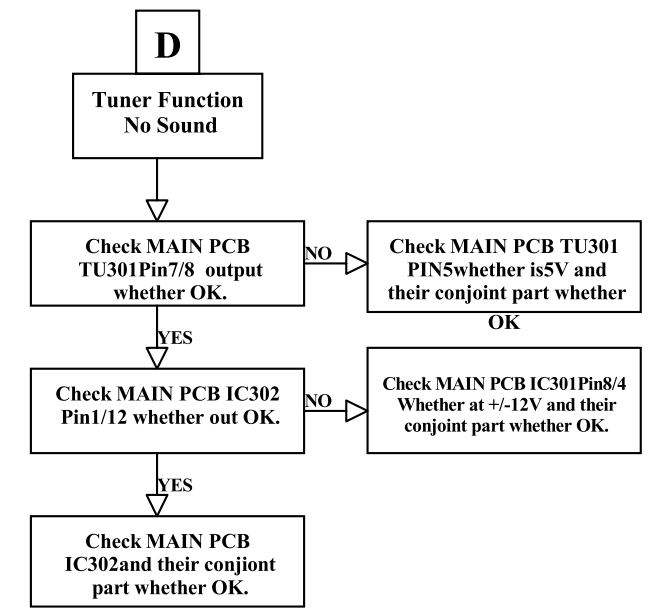
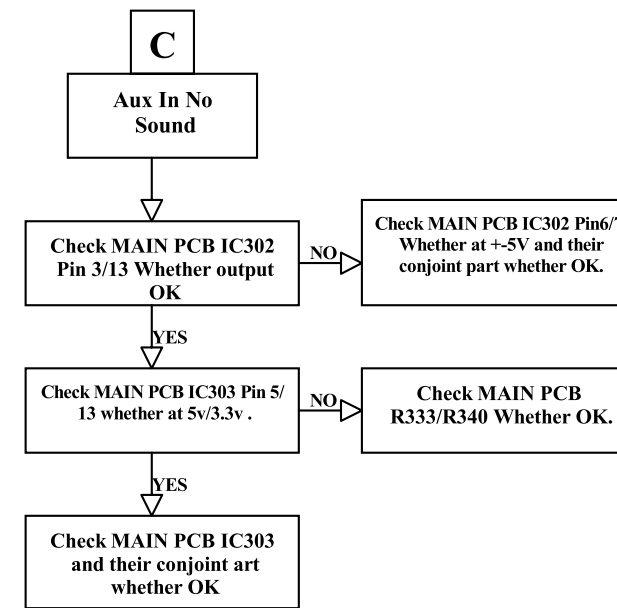
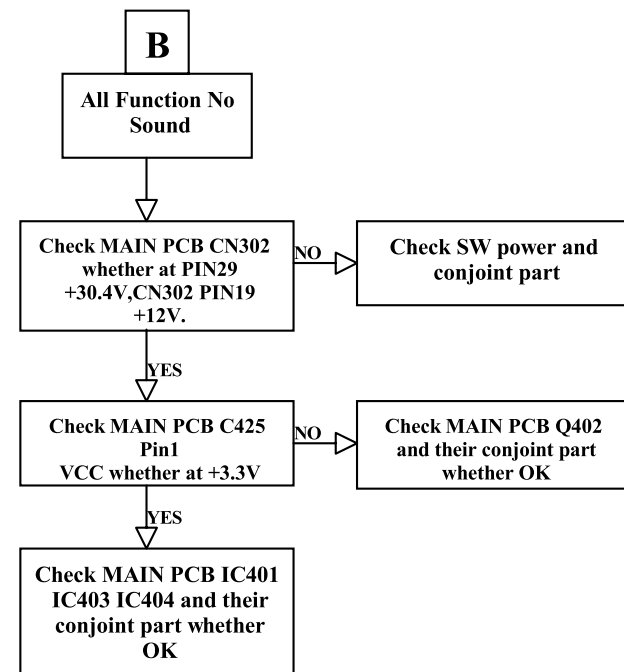
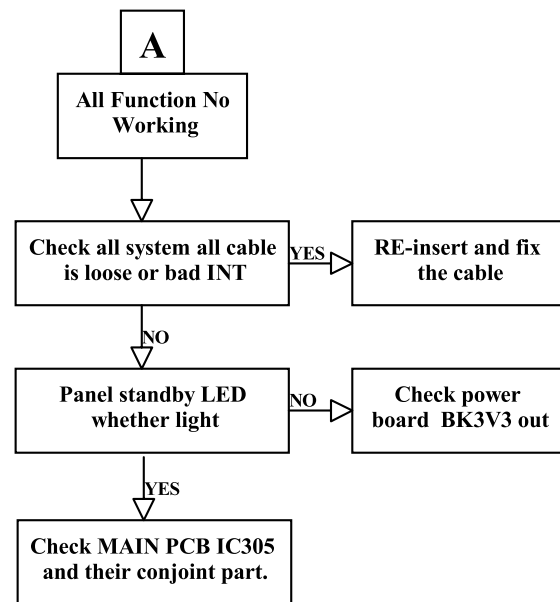
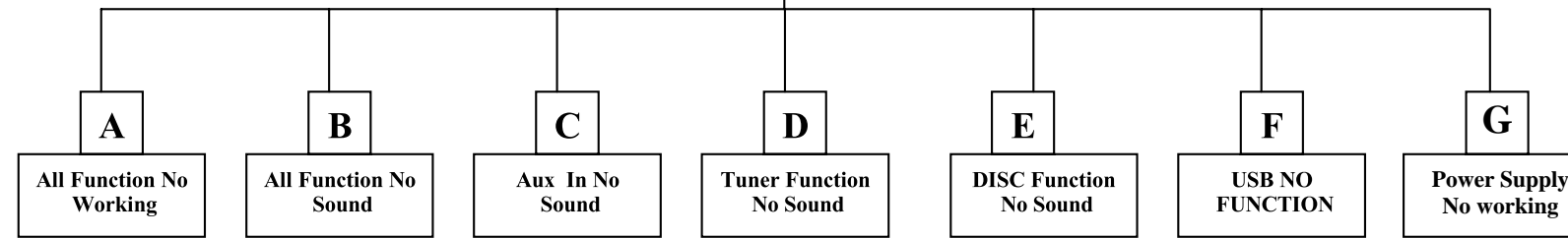

# DISASSEMBLY INSTRUCTIONS

## Dismantling of the Top & Front Panel Assemble

- 1) Open the DVD Tray by using the Open/Close Button while the Set is ON and disconnect the mains supply after removing the Tray Cover.  
*Note: If this is not possible, the DVD Tray has to be open manually.*  
Take a mini screw driver about 2mm diameter and make a marking 24mm from the tip as shown in figure 2 . Place the set on its side, insert the mini screw driver till the marking and slide it towards the left as shown in figure 1 until the Tray moves out of the Front Panel.
- 2) Return the set to its upright position and remove the Tray Cover as shown in Figure 3 and close the tray manually by pushing it back in.

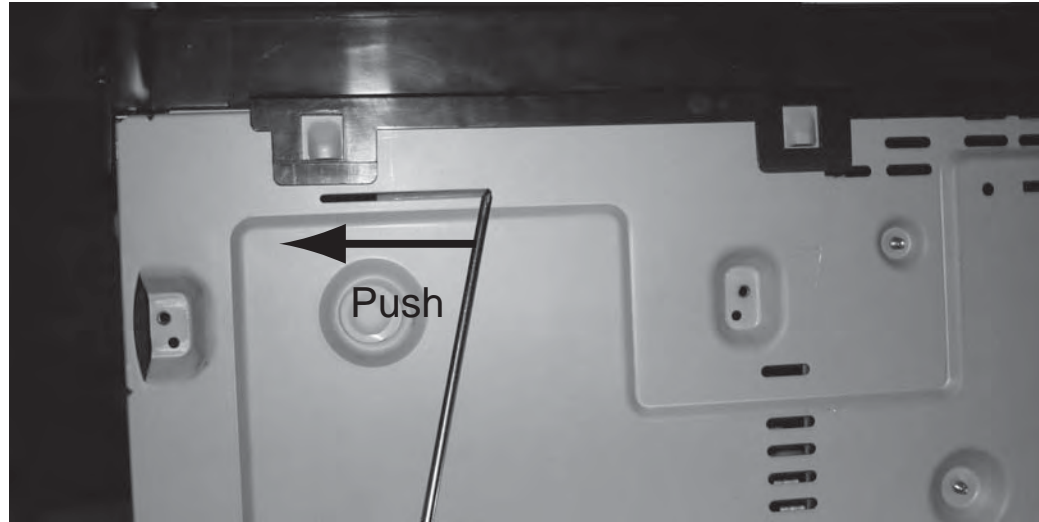

Figure 1

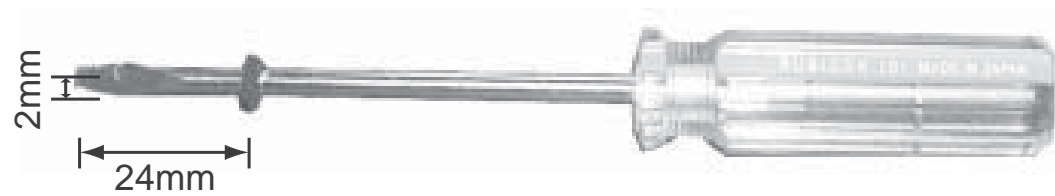

Figure 2

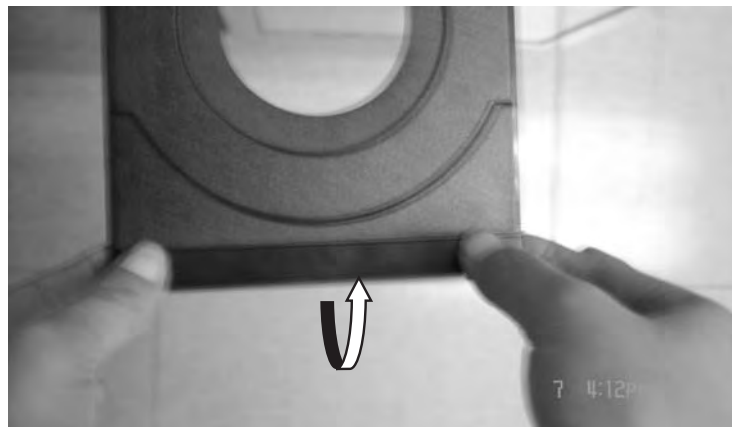

Figure 3

- 3) Loosen 6 screws and remove the Top Cover by lifting the rear portion upwards before sliding it out towards the rear.
  - 4 screws "A" at the back panel as shown in figure 4.
  - 1 screw "B" each on the left & right side as shown in figure 5.

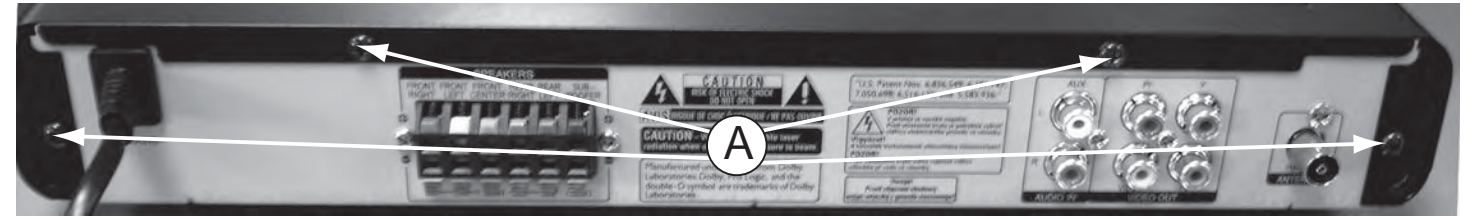

Figure 4

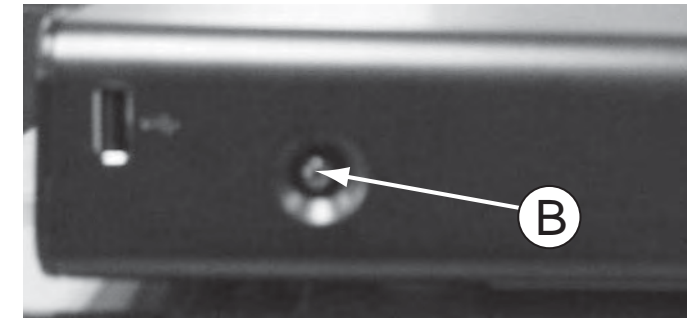

Figure 5

## Dismantling of the DVD Loader Module

- 1) Loosen 4 screws "C" at the DVD Loader Module as shown in figure 6.

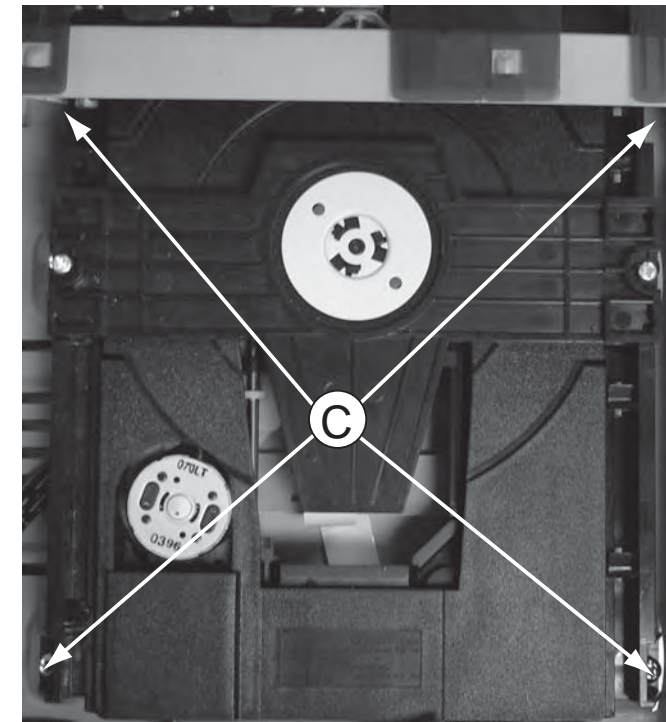

Figure 6

**Dismantling of the VFD+USB Board**

1) Loosen 7 screws "D" on the top of VFD+USB Board as shown in figure 7.

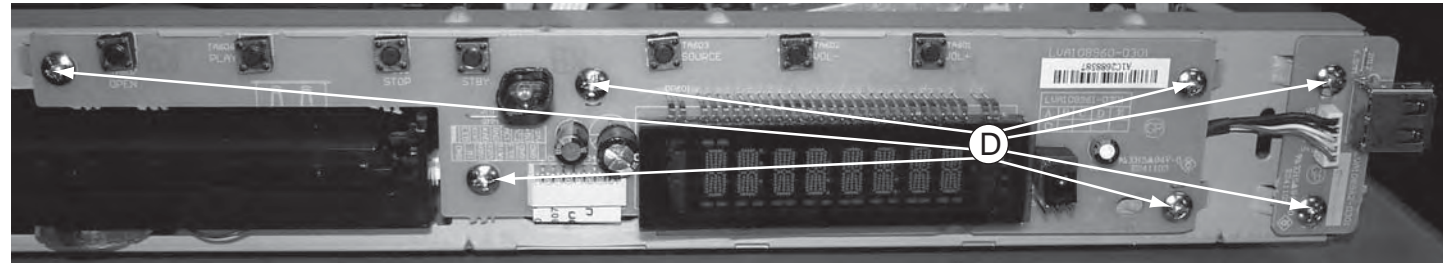

Figure 7

**Dismantling of the MAIN Board**

- 1) Loosen 4 screws "E" on the top of MAIN Board as shown in figure 8.
- 2) Loosen 5 screws "F" at the back panel as shown in figure 9.

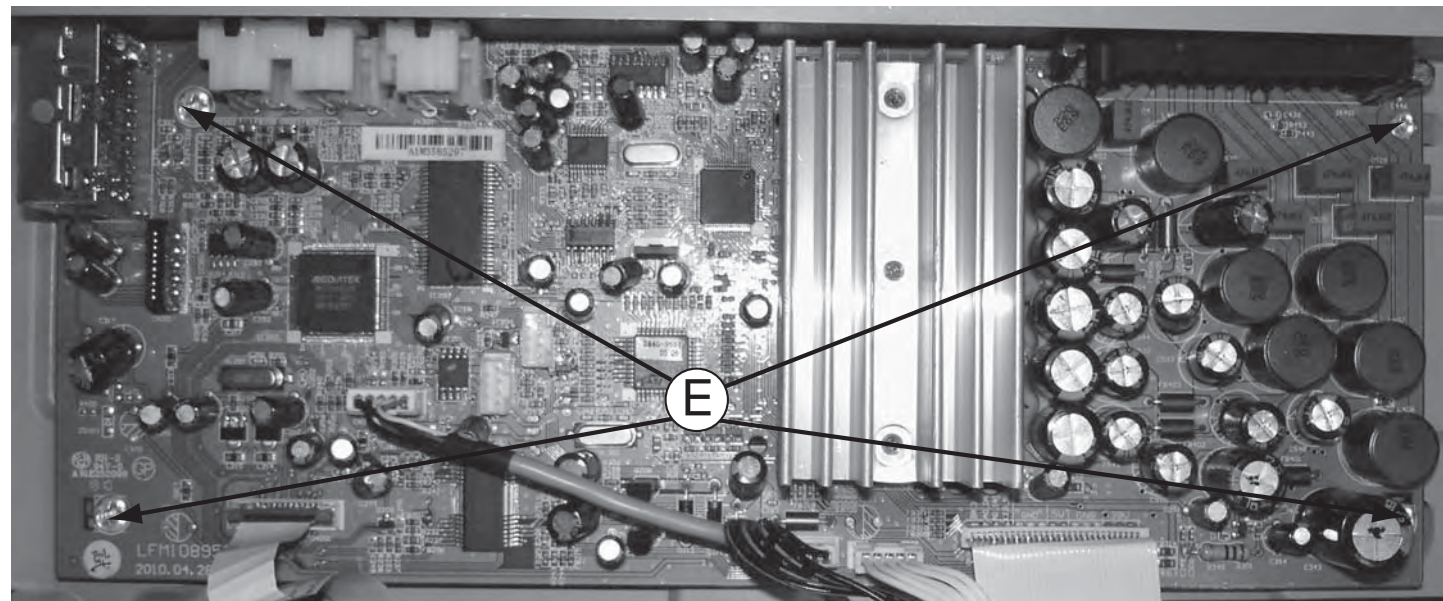

Figure 8

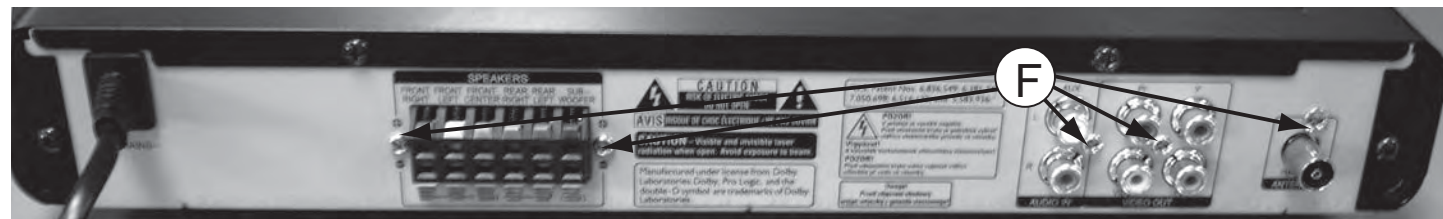

Figure 9

**Dismantling of the POWER Board**

1) Loosen 5 screws "G" on the top of Power Board as shown in figure 10.

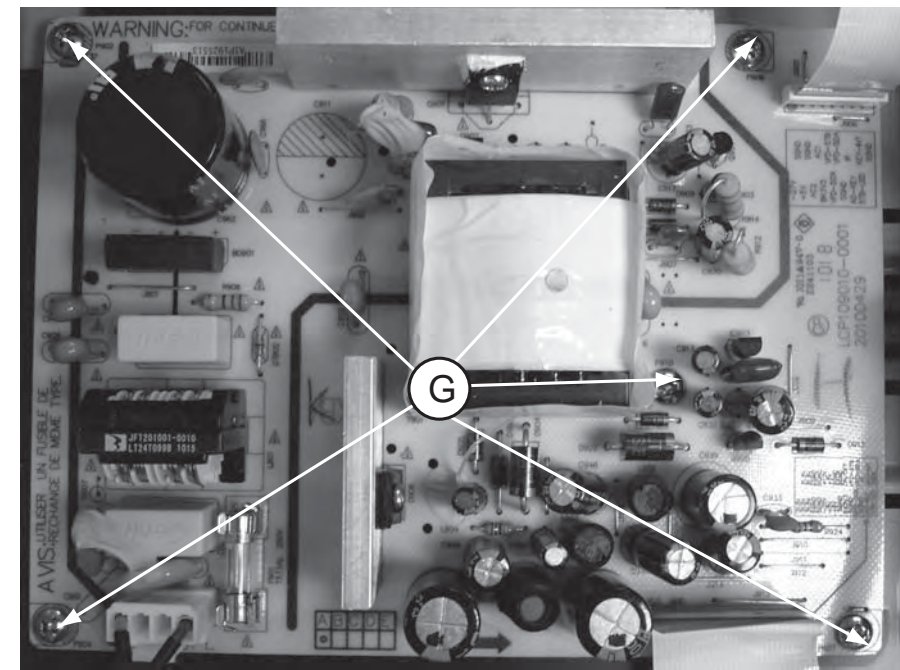
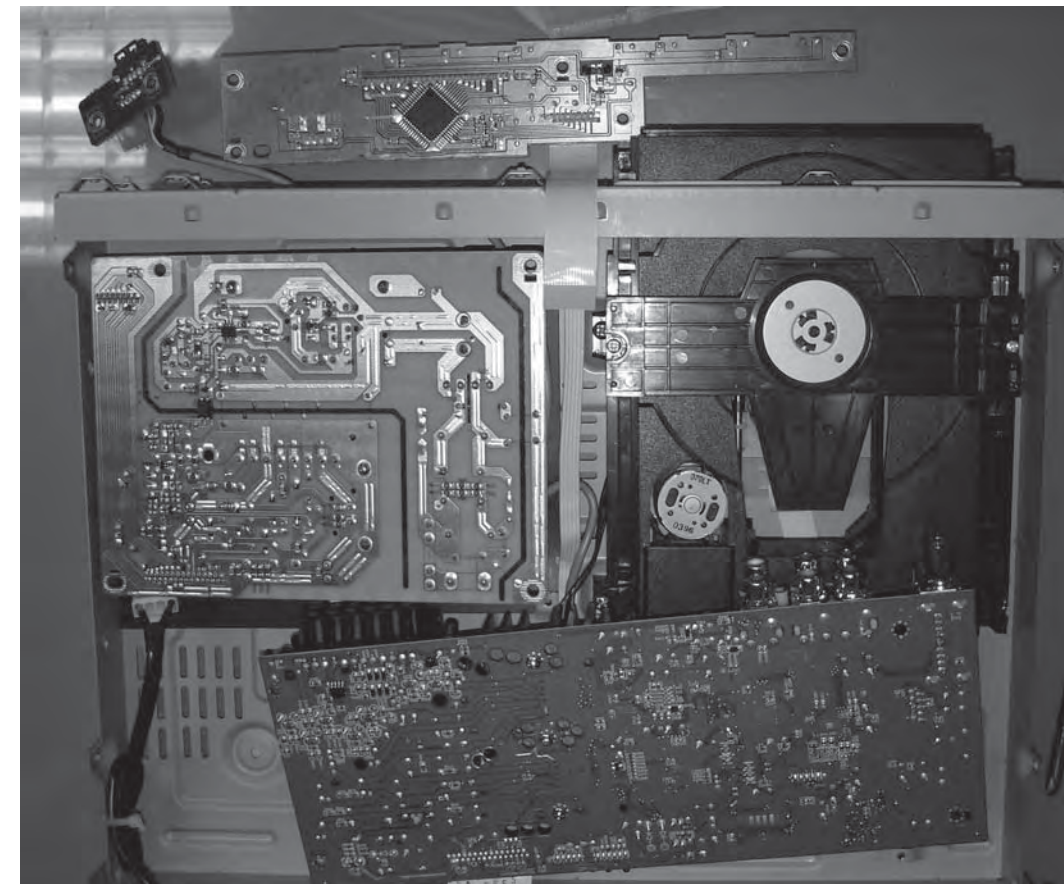

Figure 10

**SERVICE POSITIONS**



Note: In some service positions the components or copper patterns of one board may risk touching its neighbouring pc boards or metallic parts. To prevent such short-circuit use a piece of hard paper or other insulating material between them.

# CIRCUIT DIAGRAM

The following excerpt of the QSG/DFU serves as an introduction to the set.  
The complete Direction for Use can be download in the different languages from the internet site of Philips Consumer care Center: [www.support.philips.com](http://www.support.philips.com)

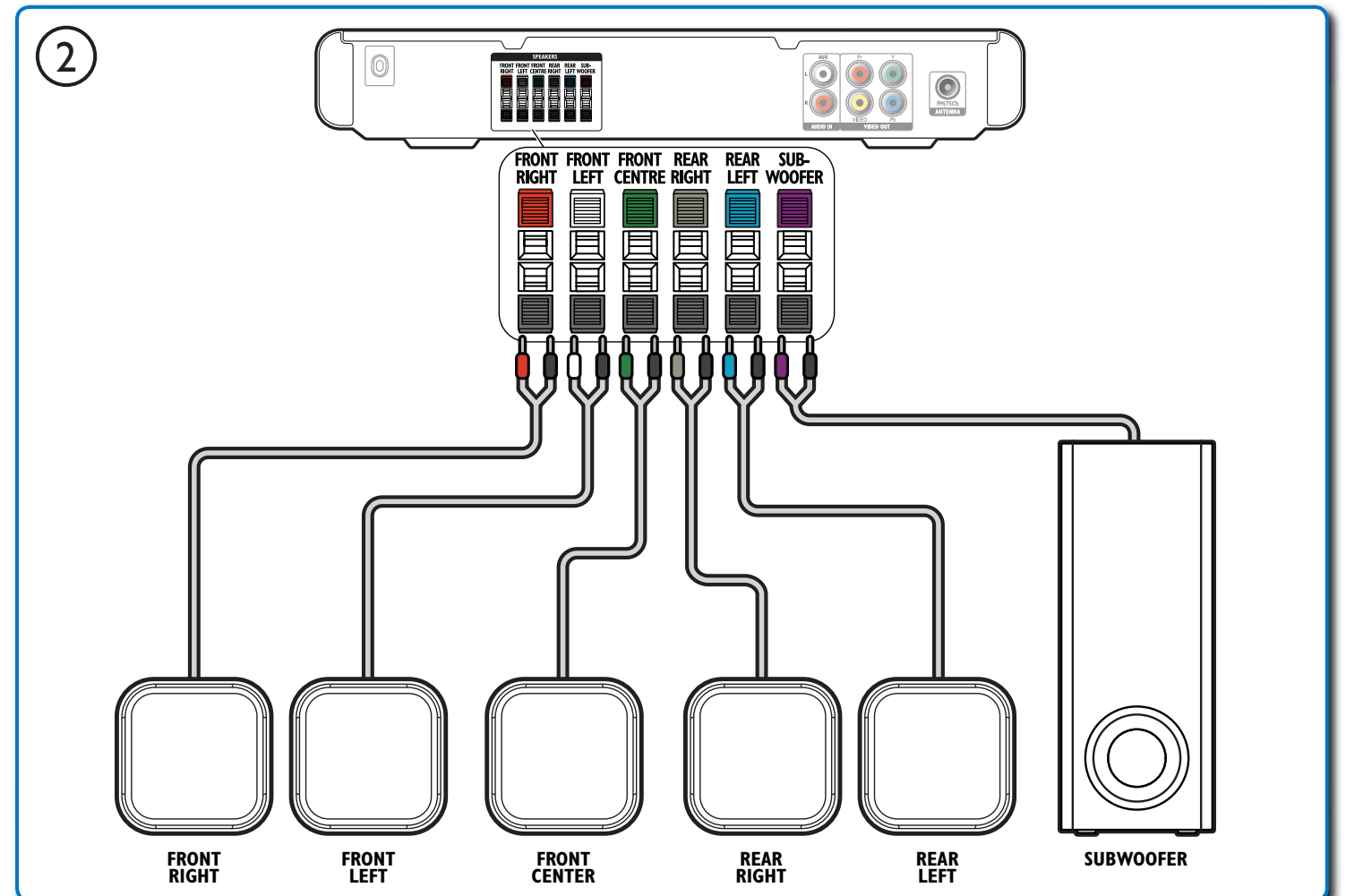
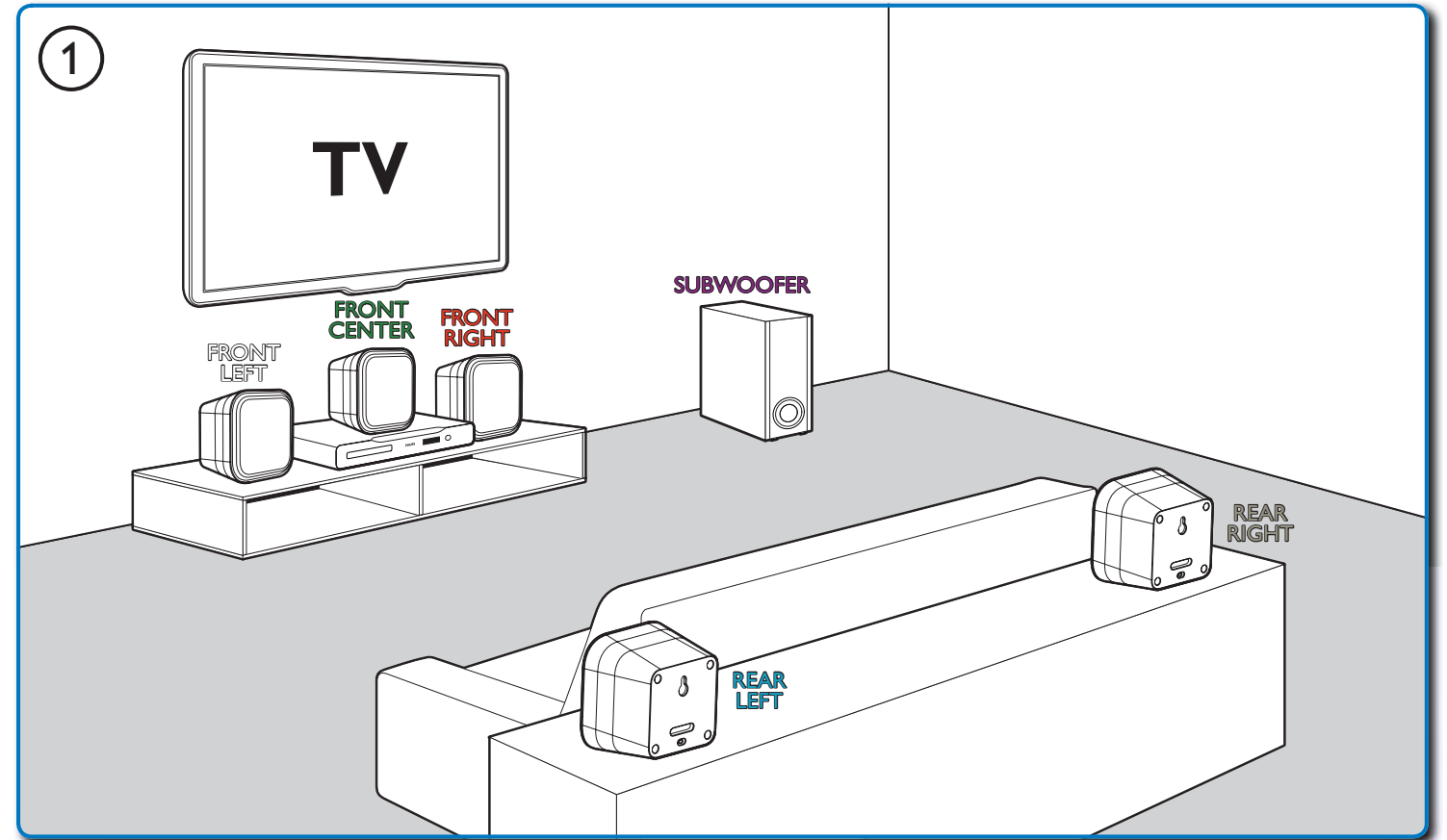
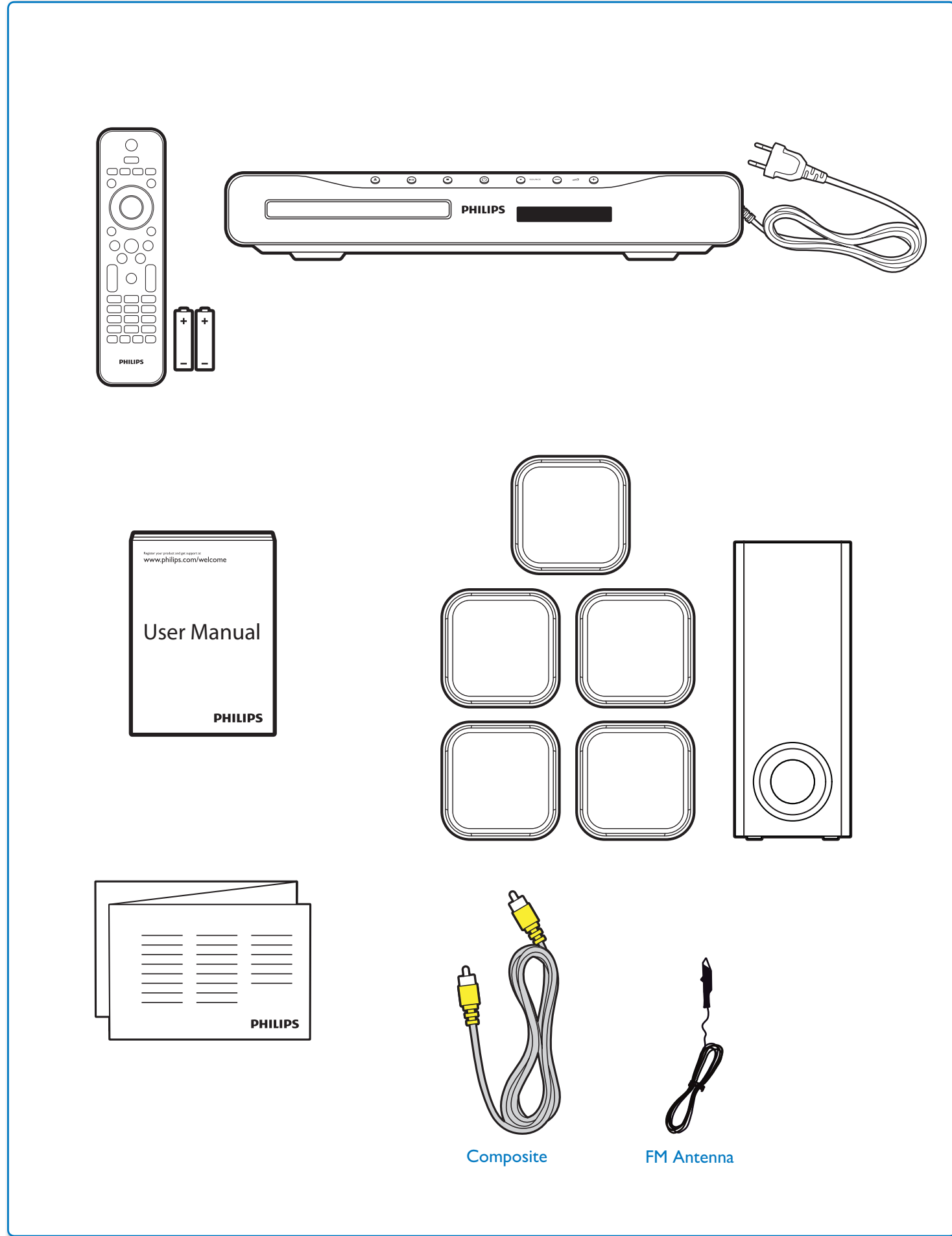

3

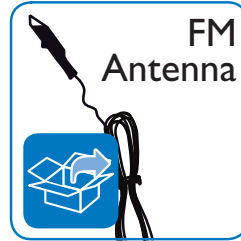
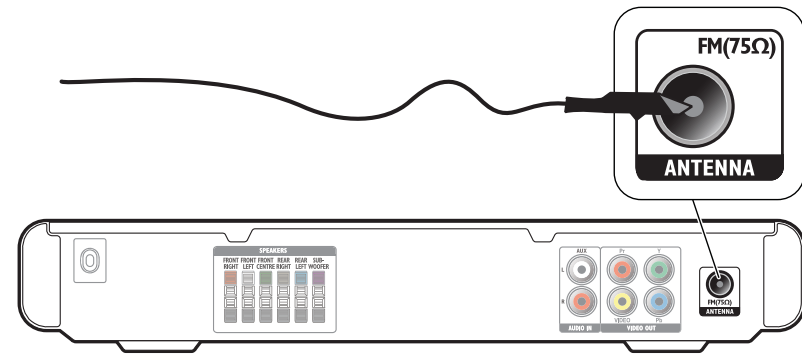

6

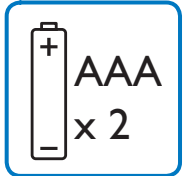
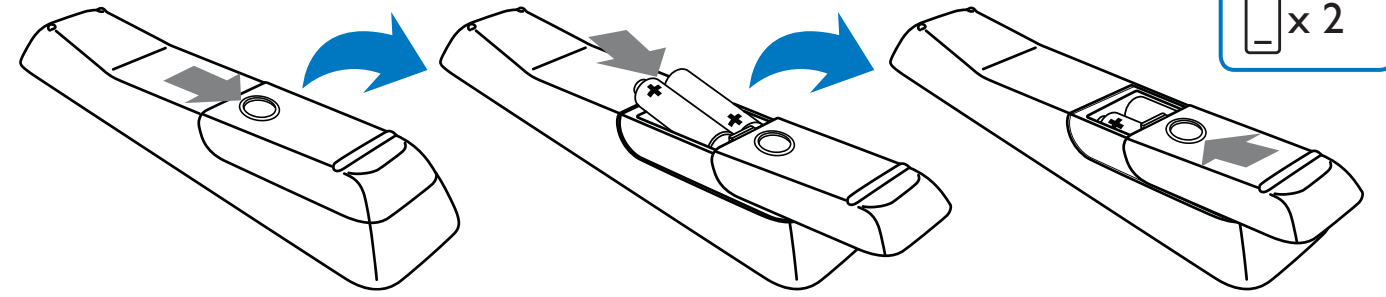

4

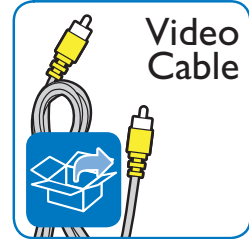
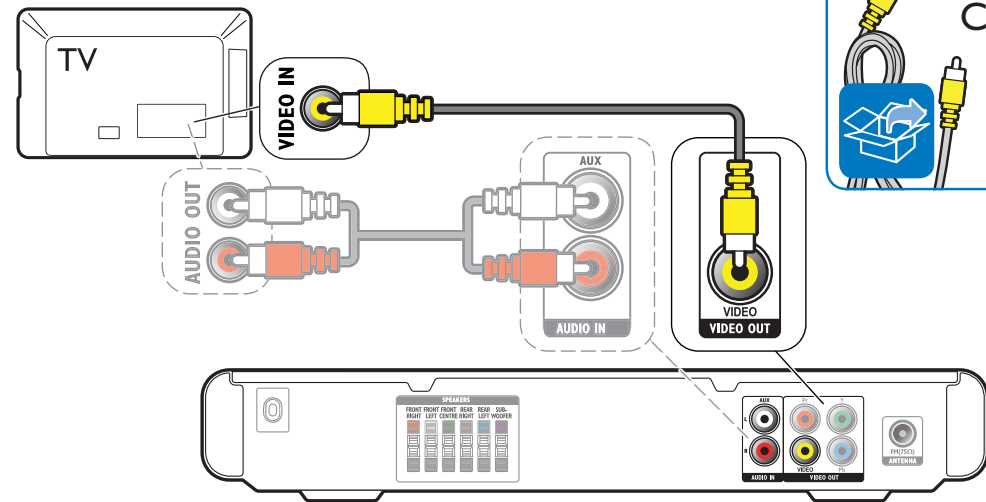

5

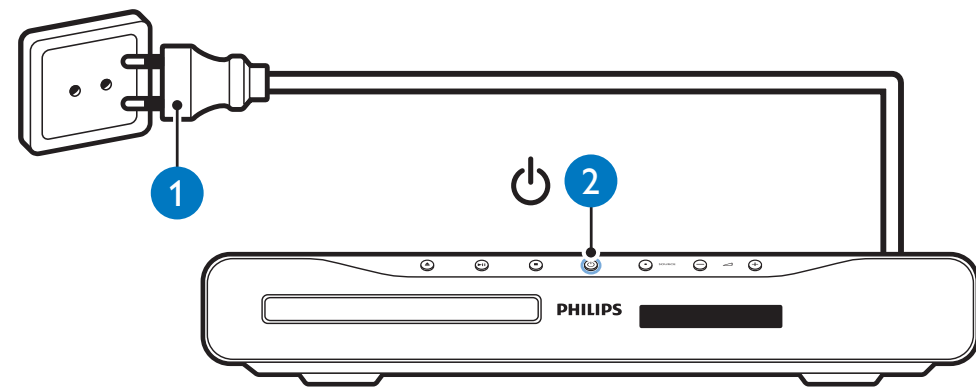

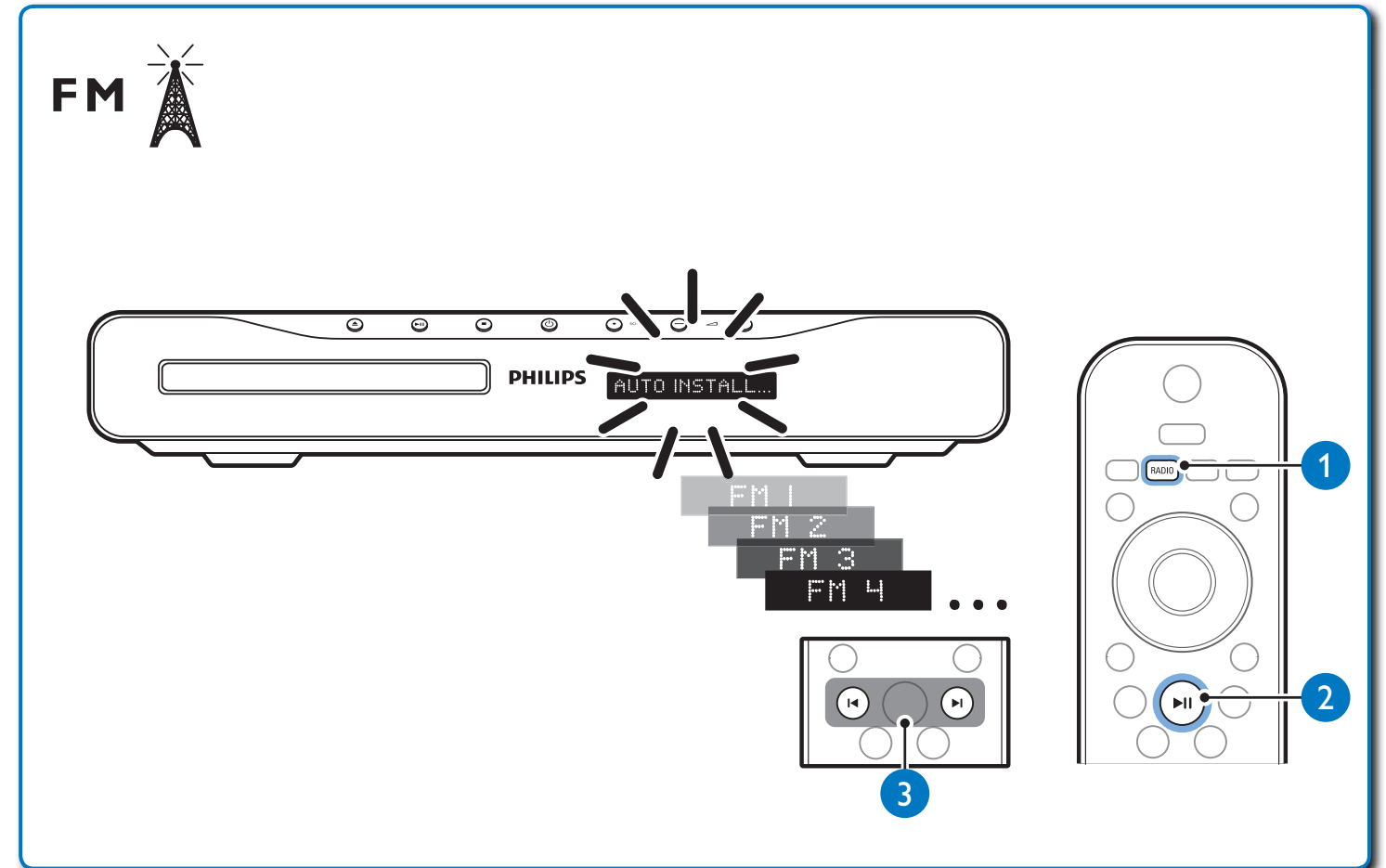
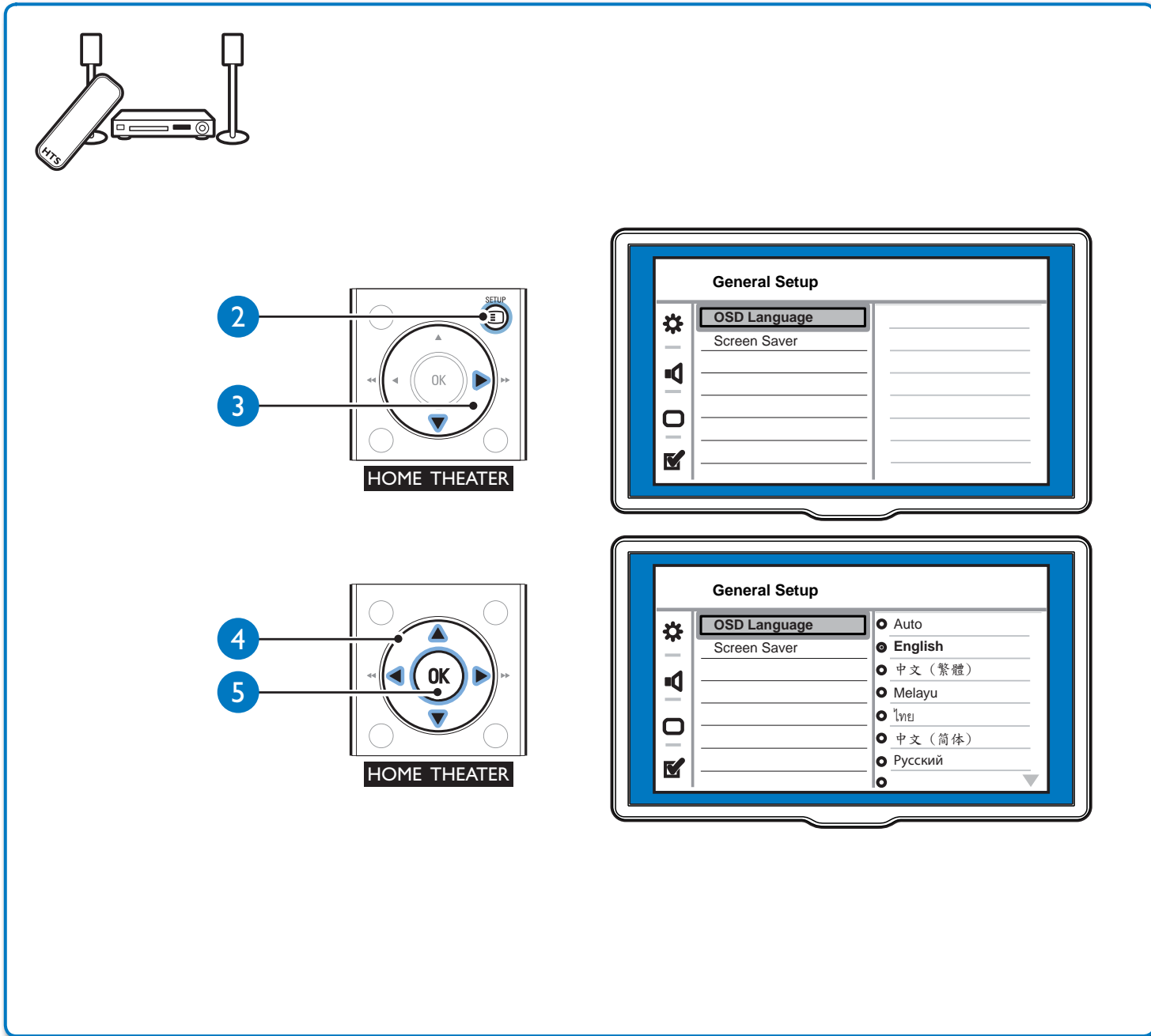
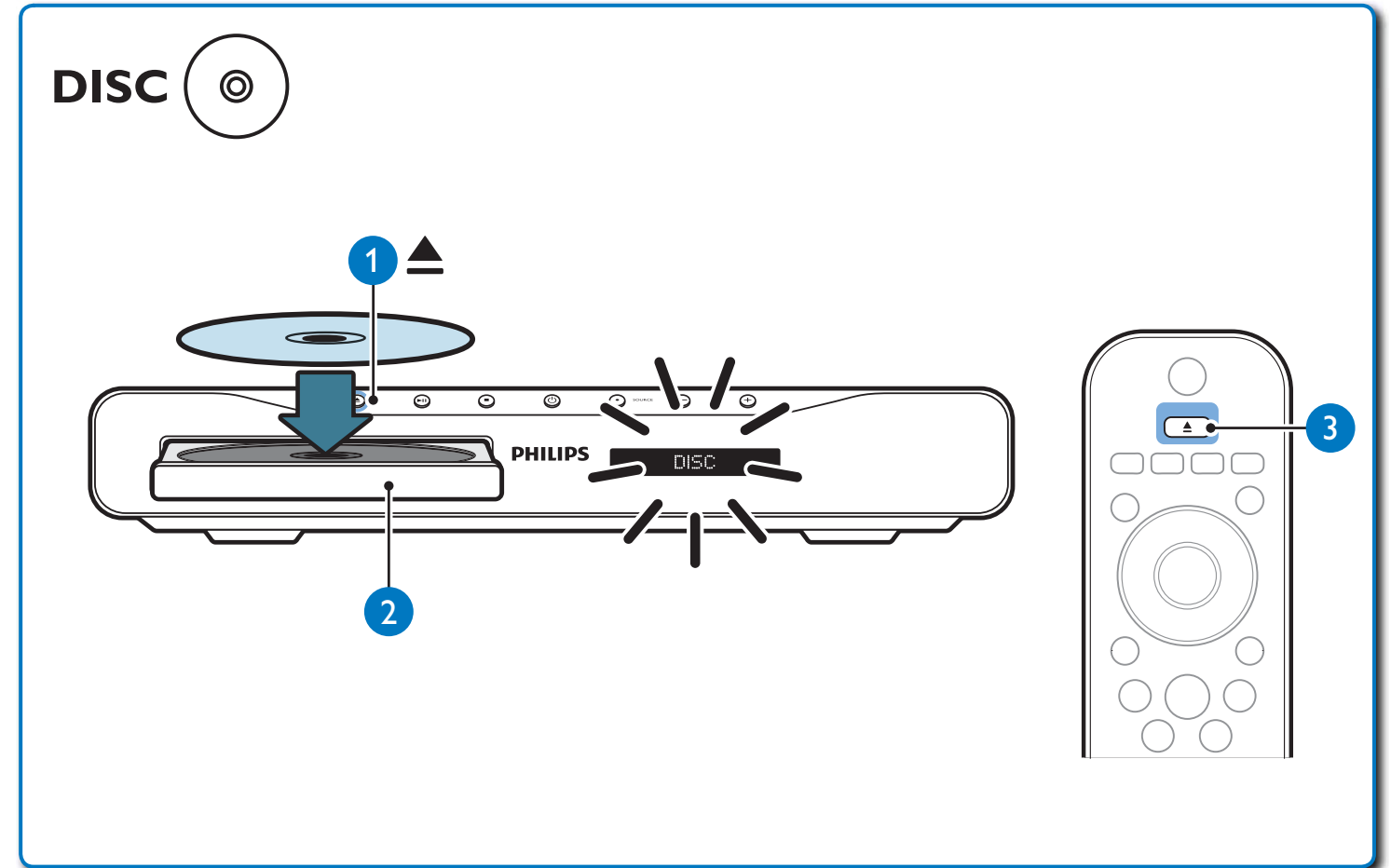
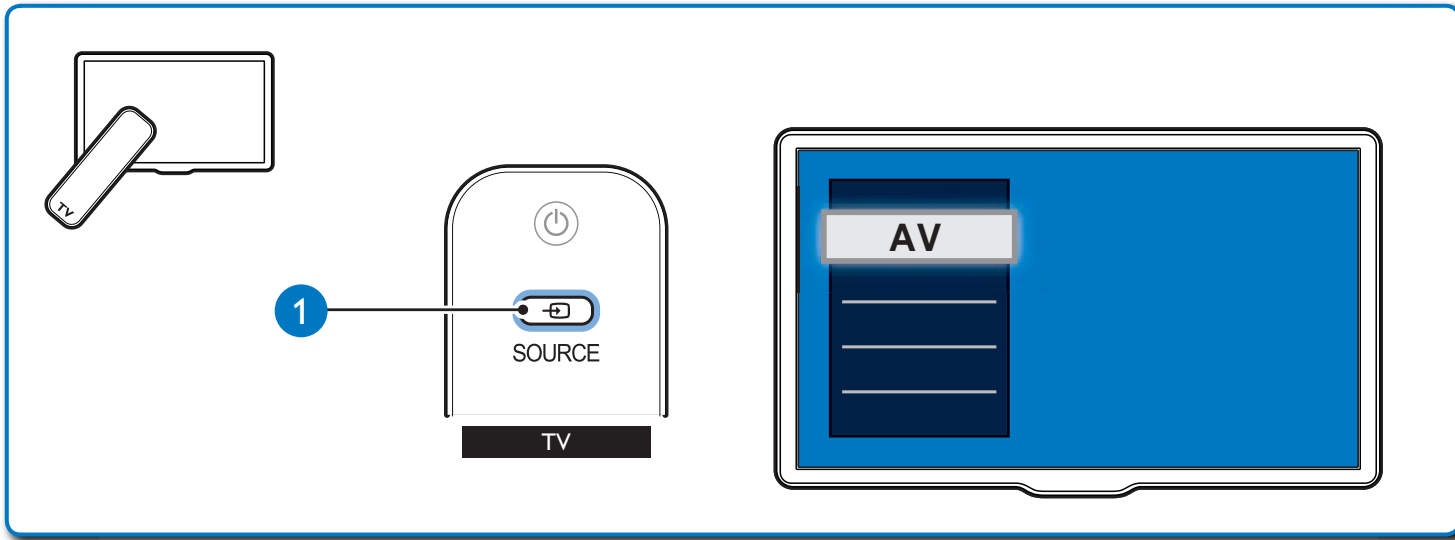

# USB

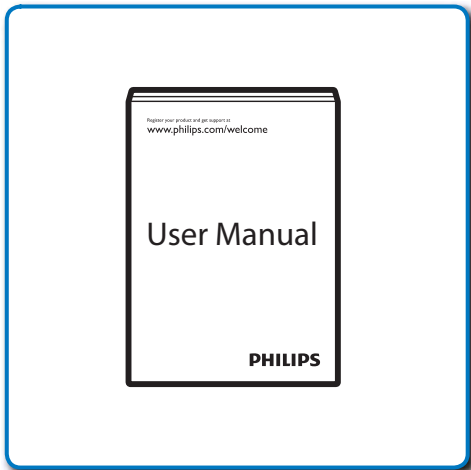
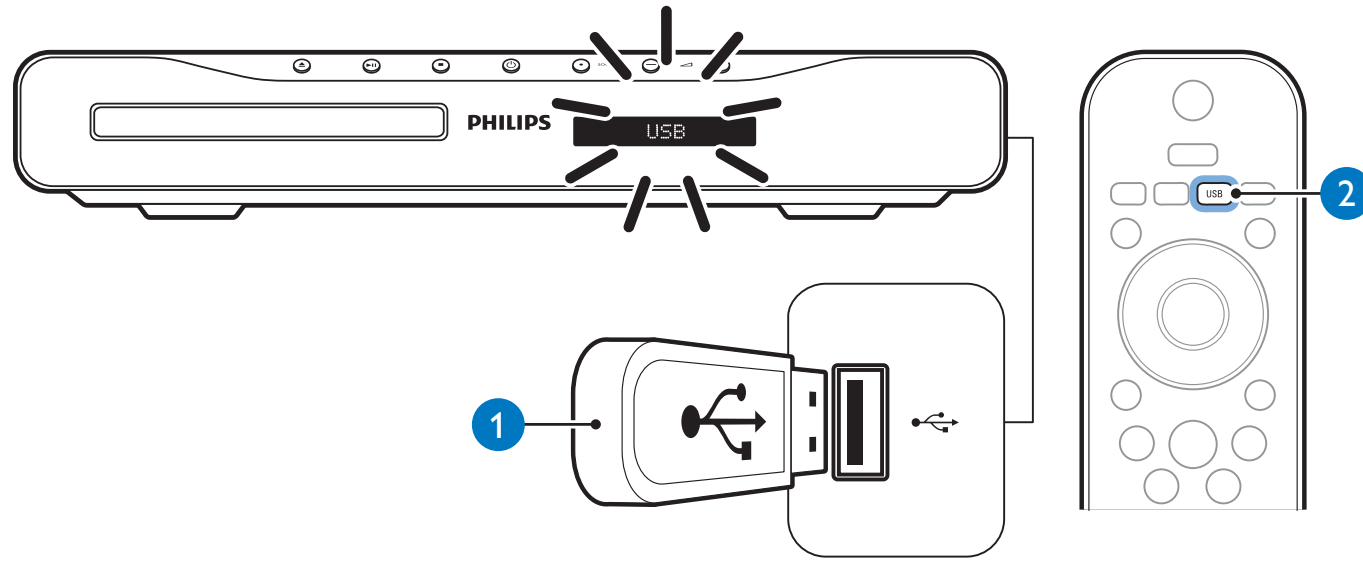

Specifications are subject to change without notice  
 Trademarks are the property of Koninklijke Philips Electronics N.V.  
 or their respective owners  
 2010 © Koninklijke Philips Electronics N.V. All rights reserved.  
 sgsna\_1021/51,94,98\_v1

 Be responsible  
 Respect copyrights



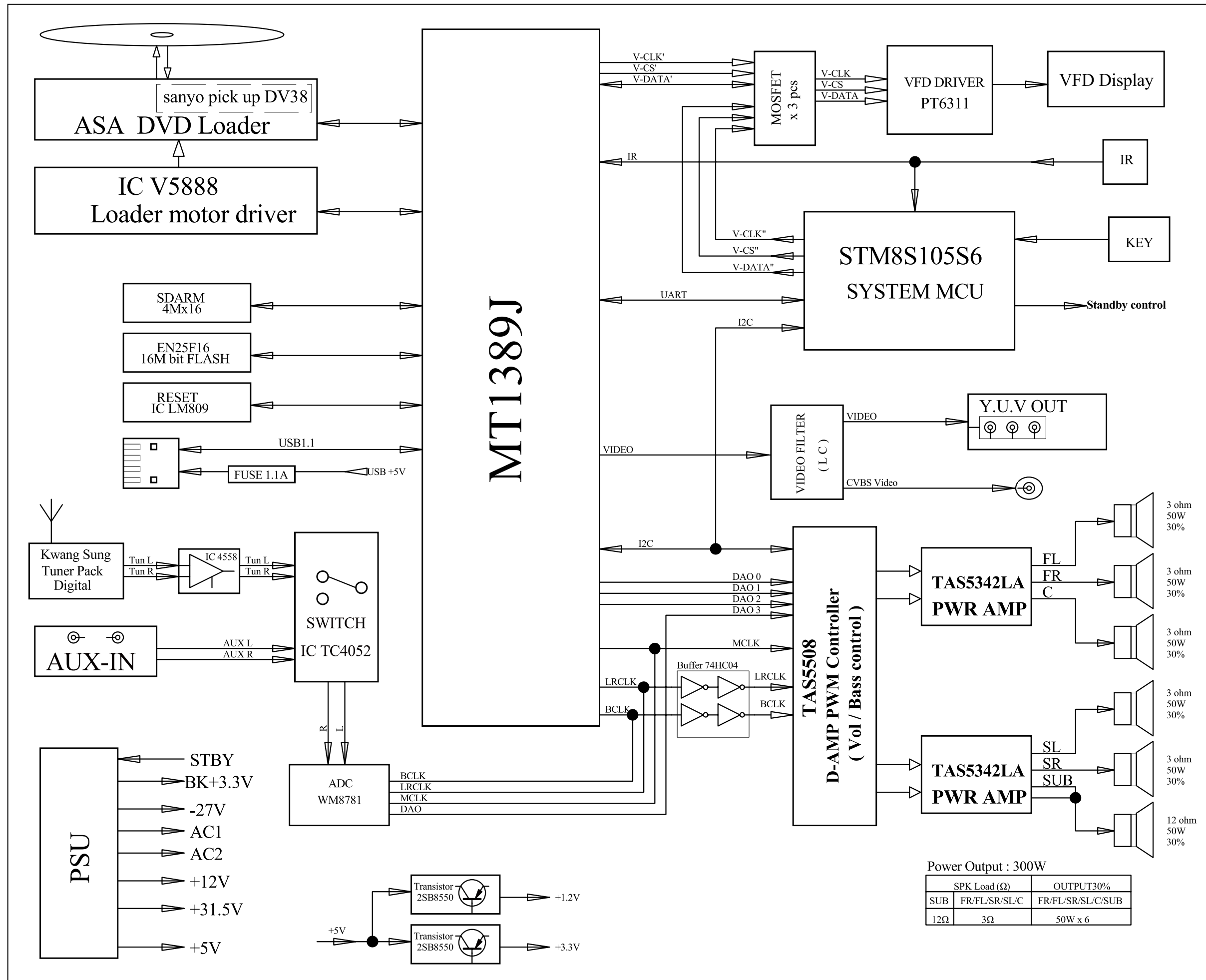



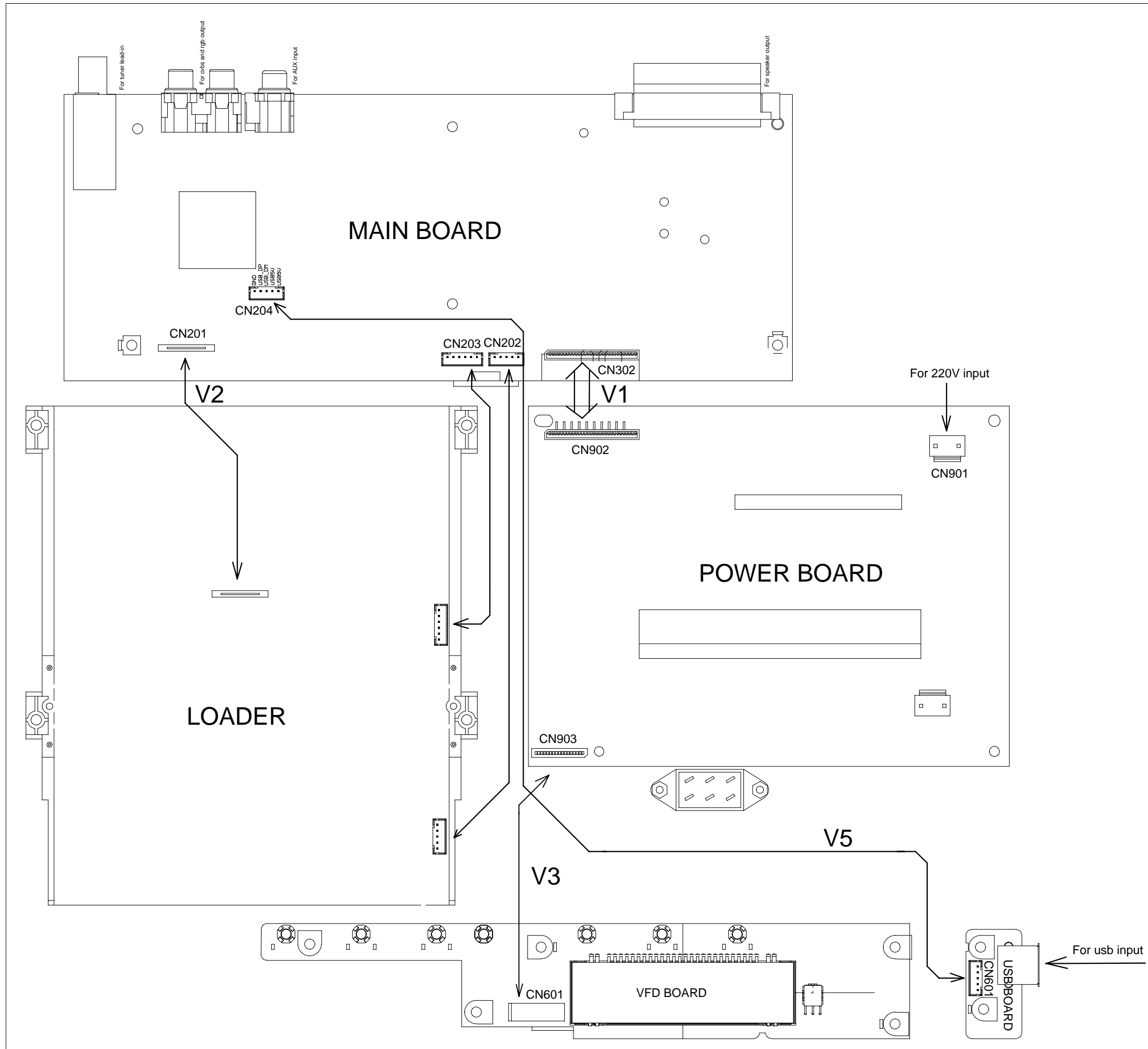

**FTD DISPLAY PIN ASSIGNMENT**

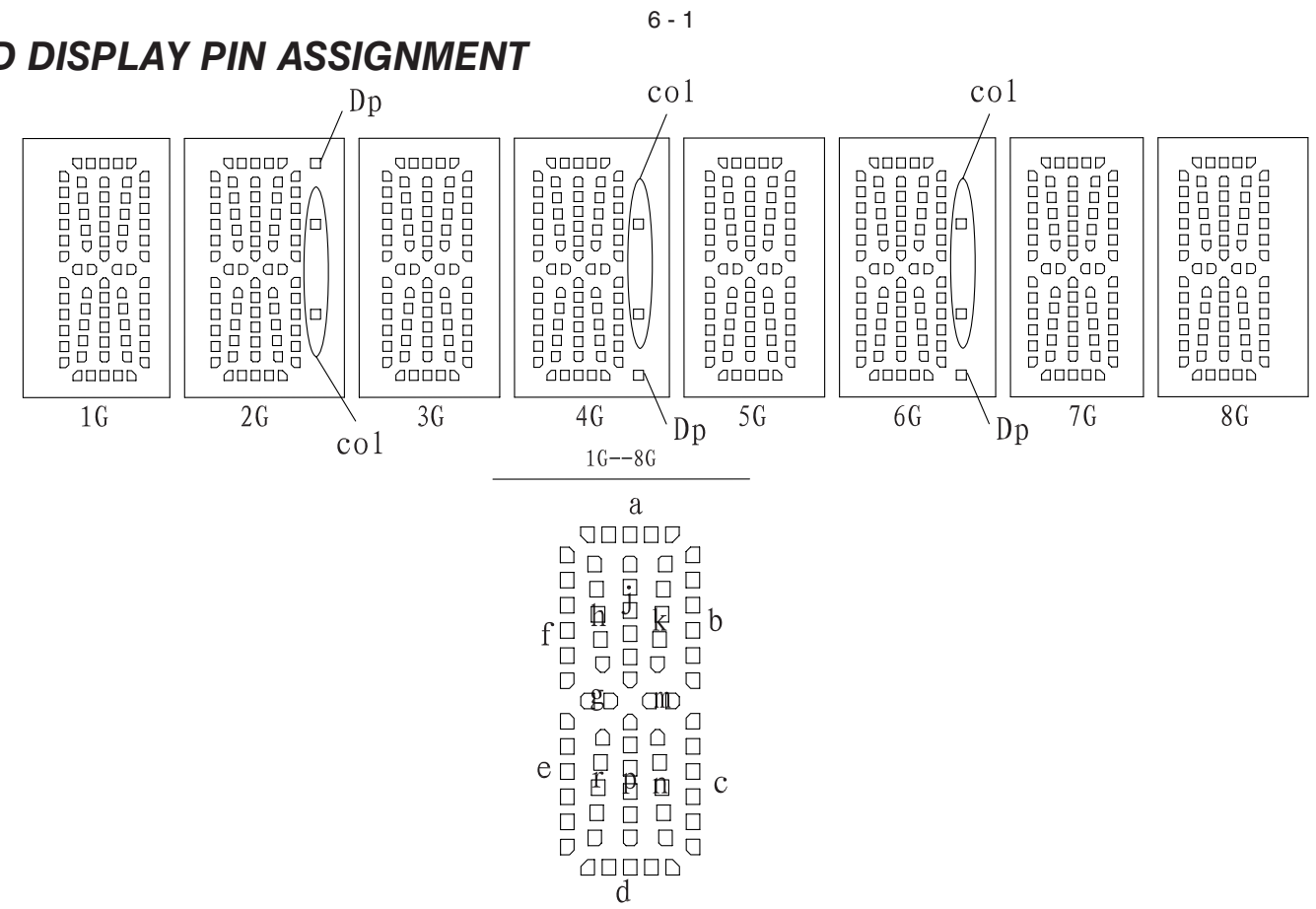

# VFD+USB BOARD

**TABLE OF CONTENTS**

FTD Display Pin Assignment.....6-1  
 Circuit Diagram .....6-2  
 PCB Layout Top & Bottom View.....6-3

	1G	2G	3G	4G	5G	6G	7G	8G
P1	a	a	a	a	a	a	a	a
P2	j, p	j, p	j, p	j, p	j, p	j, p	j, p	j, p
P3	h	h	h	h	h	h	h	h
P4	k	k	k	k	k	k	k	k
P5	b	b	b	b	b	b	b	b
P6	f	f	f	f	f	f	f	f
P7	m	m	m	m	m	m	m	m
P8	g	g	g	g	g	g	g	g
P9	c	c	c	c	c	c	c	c
P10	e	e	e	e	e	e	e	e
P11	r	r	r	r	r	r	r	r
P12	n	n	n	n	n	n	n	n
P13	d	d	d	d	d	d	d	d
P14	/	col	/	col	/	col	/	/
P15	/	Dp	/	Dp	/	Dp	/	/

**PIN CONNECTION**

(Pin NO.)	1	2	3	4	5	6	7	8	9	10	11	12	13	14	15	16
(Connection)	F1	F1	NP	NC	P15	P14	NC	P13	P12	P11	P10	P9	P8	P7	P6	P5
(Pin NO.)	17	18	19	20	21	22	23	24	25	26	27	28	29	30	31	32
(Connection)	P4	P3	P2	P1	NC	1G	2G	3G	4G	5G	6G	7G	8G	NP	F2	F2

(Notes) : Fn : (Filament Pin)      nG : (Grid Pin)  
 Pn : (Anode Pin)                      NP : (No Pin)  
 NC : (No connection Pin)

# CIRCUIT DIAGRAM

C601 B1 C604 B1 C607 B2 C610 A2 C613 C1 C616 B2 DP601 A2 Q601 A2 R602 A1 R605 A1 R608 A2 R611 B1 R614 B2 R617 C1 R620 D1 R623 C1 SN601 A2 TA603 A1 TA606 A2  
 C602 B2 C605 B2 C608 B2 C611 B3 C614 C1 CN601 B1 IC601 C2 Q602 B1 R603 A1 R606 A1 R609 A2 R612 B1 R615 B2 R618 C1 R621 D1 R624 C1 TA601 A1 TA604 A1 TA607 A2  
 C603 D1 C606 B2 C609 C2 C612 C1 C615 C2 CN602 D1 LD601 A1 R601 A1 R604 A1 R607 A2 R610 B3 R613 B1 R616 C1 R619 D1 R622 C1 R625 C1 TA602 A1 TA605 A2 USB601 D1

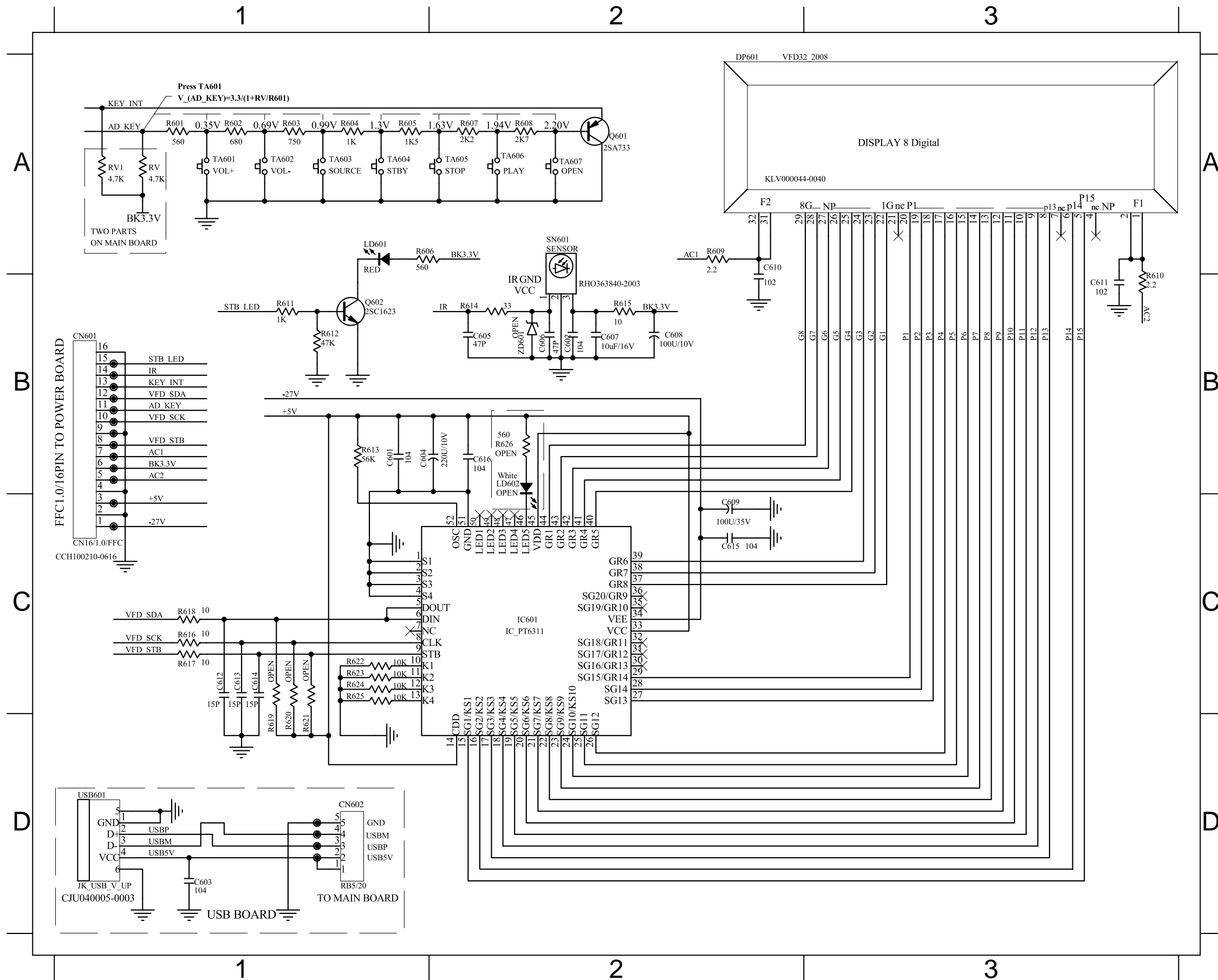

### PCB LAYOUT - TOP VIEW

C604 A2 C609 A2 CN602 A1 JM1 A3 JM12 A2 JM6 A3 JM8 A3 LD601 A2 TA601 A4 TA603 A3 TA605 A2 TA607 A1  
 C608 A4 CN601 A2 DP601 A3 JM10 A2 JM3 A3 JM7 A3 JM9 A3 SN601 A4 TA602 A3 TA604 A2 TA606 A1 USB601 A1

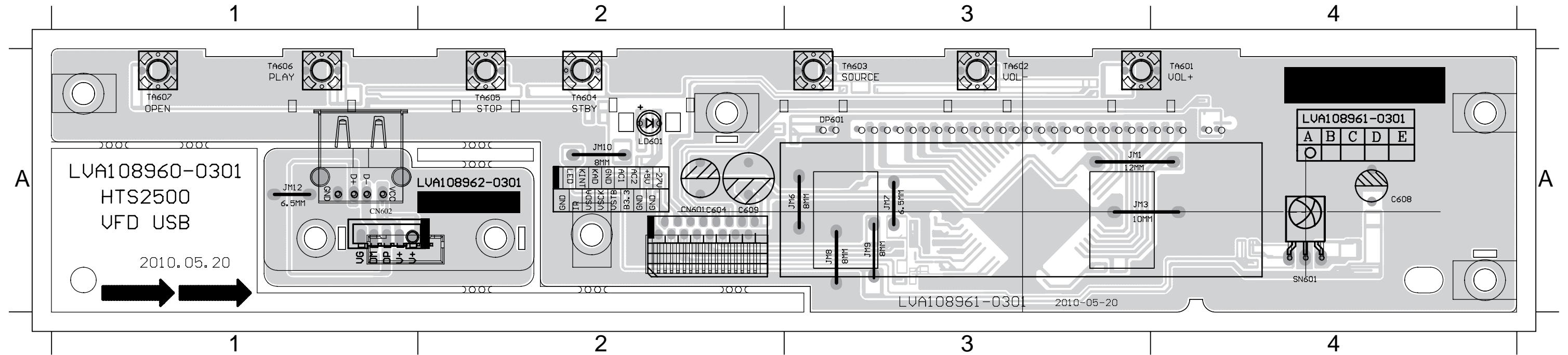

### PCB LAYOUT - BOTTOM VIEW

C601 A3 C603 A1 C606 A4 C610 A4 C612 A3 C614 A3 C616 A3 Q601 A2 R601 A3 R603 A3 R605 A2 R607 A1 R609 A4 R611 A2 R613 A3 R615 A4 R617 A3 R619 A3 R621 A3 R623 A3 R625 A3  
 C602 A4 C605 A4 C607 A4 C611 A3 C613 A3 C615 A2 IC601 A3 Q602 A2 R602 A3 R604 A3 R606 A2 R608 A1 R610 A3 R612 A2 R614 A4 R616 A3 R618 A3 R620 A3 R622 A3 R624 A3

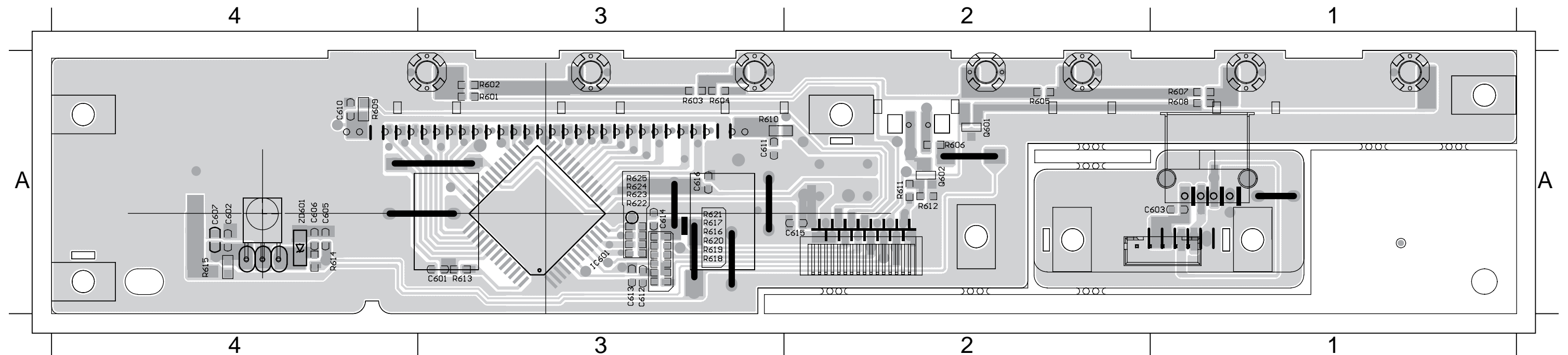

# MAIN+LED BOARD

## TABLE OF CONTENTS

Internal IC Diagram ..... 7-1  
 Circuit Diagram(part one) ..... 7-2  
 Circuit Diagram(part two)..... 7-3  
 Circuit Diagram(part three) ..... 7-4  
 PCB Layout Top View ..... 7-5  
 PCB Layout Bottom View ..... 7-6

7 - 1  
**INTERNAL IC DIAGRAM - MT1389DXE/J**

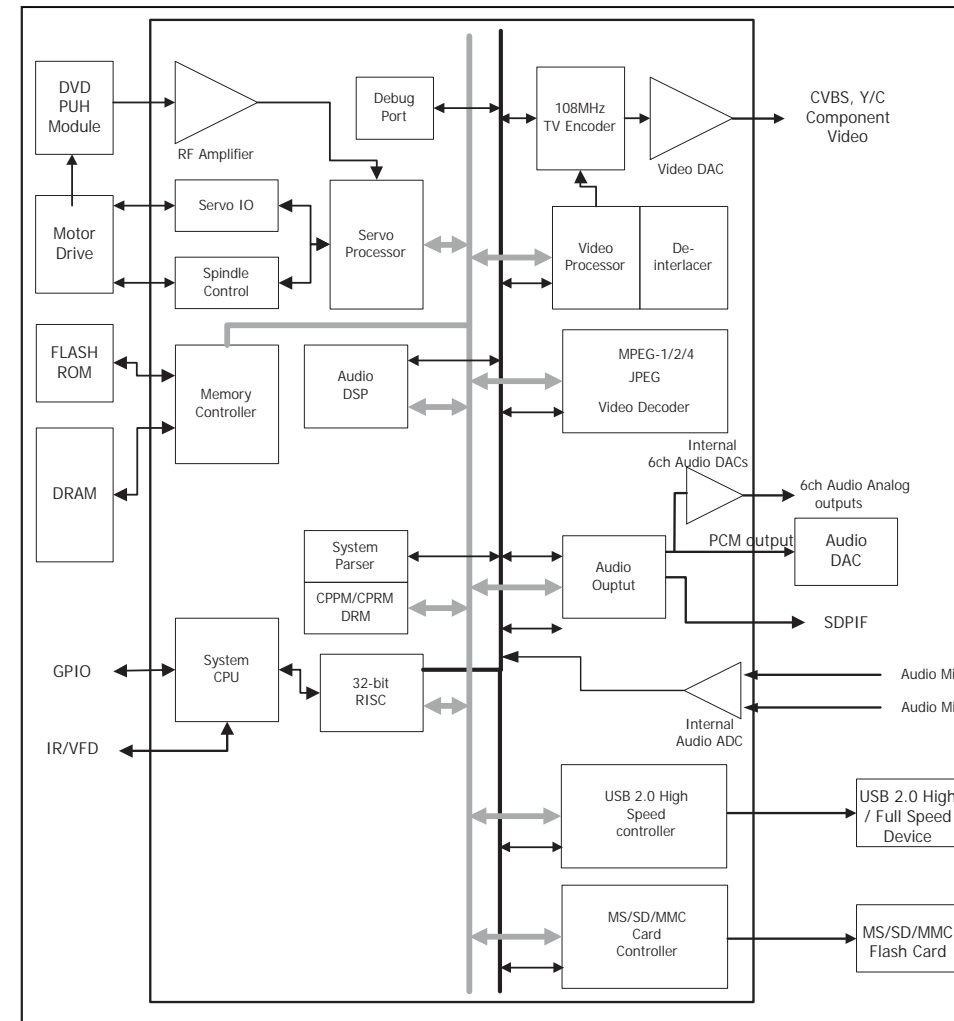

**INTERNAL IC DIAGRAM - TAS5508BPAG**

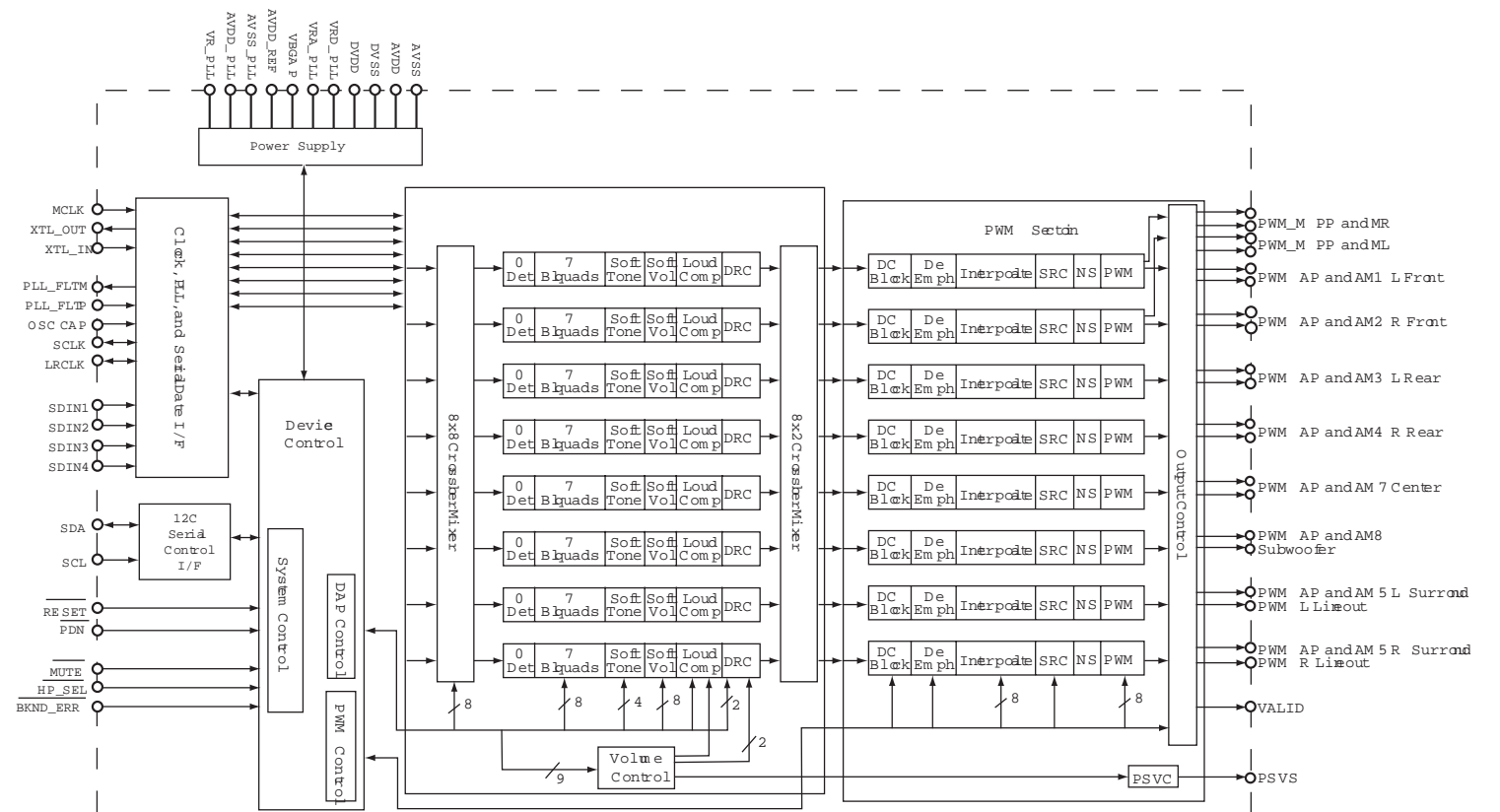

# CIRCUIT DIAGRAM - part one

C401 D1 C413 B2 C427 B1 C440 C1 C452 D2 C465 D3 C477 A3 C489 D4 C501 D3 C513 C4 C525 B4 C541 C4 D402 C2 FB405 B1 L406 C4 R407 B2 R419 B2 R431 D3 R444 B2 R458 C1 R472 A3 R486 A4 R500 A4 R512 B3 R525 D2  
 C402 A1 C414 B2 C428 B2 C441 C1 C454 C2 C466 C3 C478 B3 C490 D4 C502 D4 C514 C4 C526 B4 C542 A3 D403 C2 FB406 B1 L407 D3 R408 A1 R420 B2 R432 A2 R445 B2 R459 C1 R473 A3 R487 B4 R501 A4 R513 D3 XL401 B1  
 C403 A1 C415 A1 C429 B2 C442 C1 C455 D1 C467 D3 C479 B3 C491 D4 C503 D4 C515 C4 C527 C4 C543 D3 D404 C2 FB407 D1 L408 D4 R409 A1 R421 A1 R433 C2 R446 A4 R460 C2 R474 B3 R488 B4 R502 B4 R514 B4 ZD401 B1  
 C404 A1 C416 A1 C430 B2 C443 C1 C456 D1 C468 D3 C480 B4 C492 A3 C504 A4 C516 D4 C528 D4 C544 B4 D407 C2 IC401 A2 Q401 D1 R410 A1 R422 A1 R434 A2 R449 C1 R462 C2 R475 B3 R489 C4 R503 B4 R515 B4 ZD402 C2  
 C405 A1 C417 A1 C431 B2 C444 C1 C457 C2 C469 D3 C481 B4 C493 A3 C505 A4 C517 D4 C529 D4 C545 B4 D408 D2 IC402 B2 Q402 B1 R411 A1 R423 A1 R435 B2 R450 C1 R463 C2 R476 C3 R490 D4 R504 B4 R516 B4  
 C406 A2 C418 B1 C432 B2 C445 C1 C458 A3 C470 A3 C482 B4 C494 B3 C506 A4 C518 D4 C532 C4 C546 B4 D409 D2 IC403 A3 Q404 D2 R412 A2 R424 A2 R437 B1 R451 C2 R464 C2 R477 C3 R491 D4 R505 B4 R517 B4  
 C407 A2 C419 A1 C433 B2 C446 C1 C459 A3 C471 A3 C483 B4 C495 B3 C507 B4 C519 D4 C533 C4 C547 B4 D411 D2 IC404 C3 R401 D1 R413 B2 R425 A3 R438 B1 R452 C1 R465 C2 R478 D3 R492 A4 R506 C4 R518 D4  
 C408 B1 C420 B1 C434 B2 C447 C2 C460 B3 C472 B3 C484 C3 C496 B4 C508 B4 C520 D4 C534 A4 C548 D4 D412 C2 JK401 C4 R402 D1 R414 B2 R426 A2 R439 B1 R453 B1 R466 C2 R479 D3 R494 B4 R507 C4 R519 D4  
 C409 B1 C421 A1 C436 C1 C448 C2 C461 B3 C473 C3 C485 C3 C497 B4 C509 B4 C521 D4 C535 A4 C549 D4 FB401 B1 L401 A4 R403 A1 R415 B2 R427 B3 R440 B2 R454 C2 R467 C2 R480 A3 R495 B4 R508 D4 R520 D4  
 C410 B1 C424 B1 C437 D1 C449 C2 C462 A3 C474 C3 C486 D3 C498 C3 C510 B4 C522 A4 C536 A4 C550 D4 FB402 B1 L402 A4 R404 A1 R416 B2 R428 A2 R441 A2 R455 C2 R468 C2 R481 C3 R496 C4 R509 D4 R521 D4  
 C411 B1 C425 B1 C438 C1 C450 A4 C463 B3 C475 D3 C487 D3 C499 C3 C511 B4 C523 C4 C537 C4 C551 D4 FB403 B1 L403 B4 R405 A1 R417 B2 R429 C3 R442 C1 R456 C2 R470 D2 R484 A3 R498 D4 R510 D4 R522 C4  
 C412 B1 C426 B2 C439 A4 C451 A4 C464 C3 C476 A3 C488 D4 C500 D3 C512 B4 C524 A4 C538 C4 D401 C2 FB404 B1 L404 B4 R406 B2 R418 B2 R430 A2 R443 C1 R457 C1 R471 D1 R485 C3 R499 D4 R511 D4 R523 C4

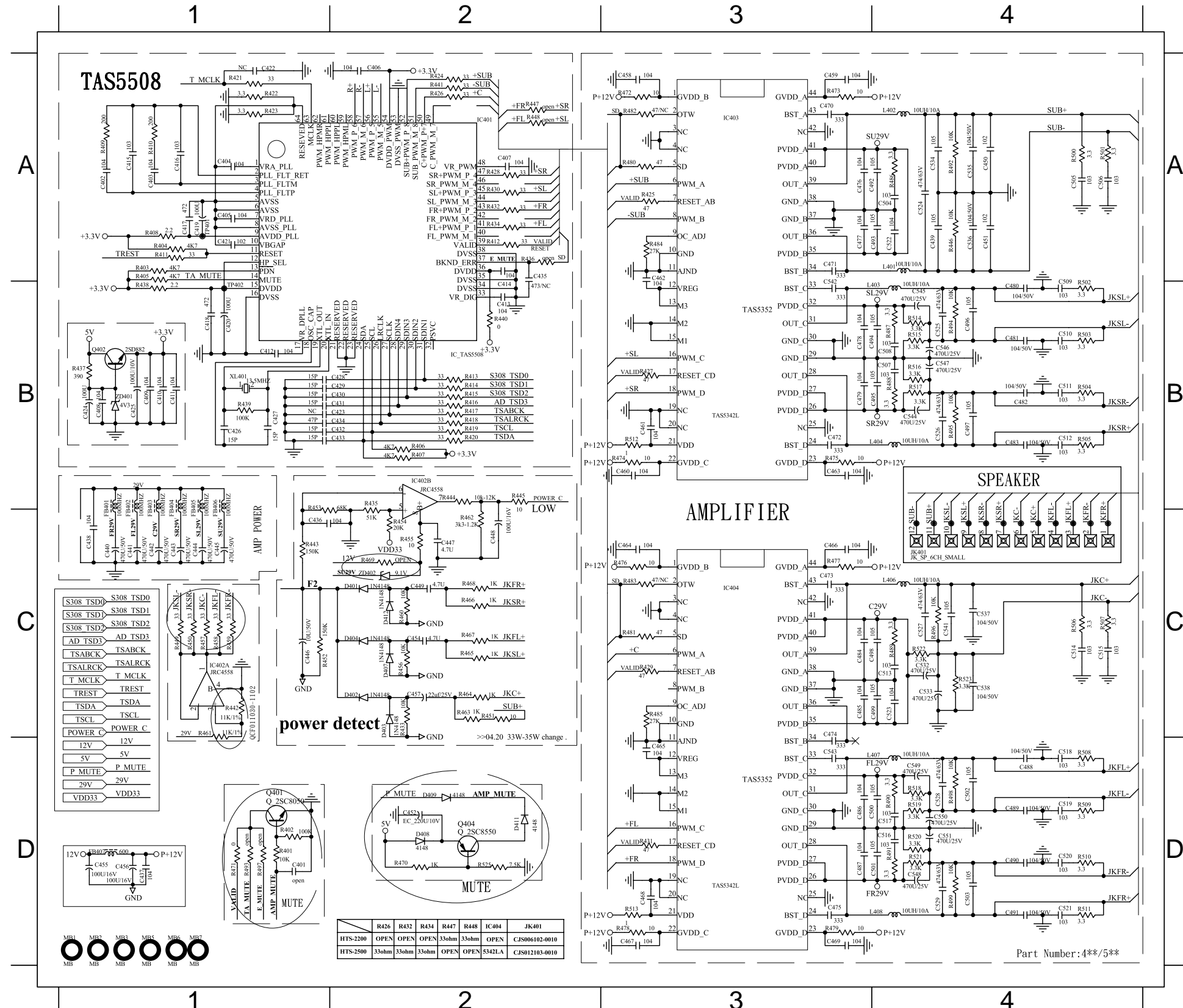

S308 TSD0	S308 TSD0
S308 TSD1	S308 TSD1
S308 TSD2	S308 TSD2
AD TSD3	AD TSD3
TSABCK	TSABCK
TSALRCK	TSALRCK
T MCLK	T MCLK
TREST	TREST
TSDA	TSDA
TSCL	TSCL
POWER C	POWER C
12V	12V
5V	5V
P MUTE	P MUTE
29V	29V
VDD33	VDD33

R426	R432	R434	R447	R448	IC404	JK401	
HTS-2200	OPEN	OPEN	OPEN	33ohm	33ohm	OPEN	CSJ080162-0010
HTS-2500	33ohm	33ohm	33ohm	OPEN	OPEN	5342LA	CSJ012163-0010



Part Number:4\*\*/5\*\*

# CIRCUIT DIAGRAM - part two

C201	A2 C209	D3 C217	A3 C225	D4 C234	A1 C242	A1 C250	C1 C259	D1 C267	D2 C275	D1 C283	B1 C291	B4 D209	C1 FB205	A1 FB214	D1 IC204	D4 L206	B4 L214	B1 R201	A2 R209	B3 R218	C3 R226	A1 R237	C1 R247	D2 R259	B1
C202	A2 C210	D3 C218	B4 C226	D3 C235	A1 C243	B1 C251	B1 C260	D1 C268	D2 C276	D2 C284	B1 C292	A4 D211	B1 FB206	D1 FB215	D1 IC205	D2 L207	D3 L215	B1 R202	B2 R211	C3 R219	D3 R227	D1 R238	C1 R250	D2 R260	B2
C203	A2 C211	D4 C219	D4 C228	D3 C236	A1 C244	B1 C252	B1 C261	D1 C269	D2 C277	D2 C285	B1 C293	B4 D212	B1 FB207	D1 FB216	D1 JK201	A2 L208	A1 L217	A4 R203	B3 R212	C3 R220	D3 R228	B4 R239	C1 R251	D2 R261	B2
C204	A2 C212	A2 C220	D4 C229	A1 C237	A1 C245	B2 C253	B1 C262	D1 C270	D3 C278	C2 C286	B1 CN201	B1 F201	C2 FB209	D1 FB217	D2 L201	A2 L209	A1 L218	A4 R204	C2 R213	C3 R221	A1 R229	B1 R240	C1 R252	C2 R262	A4
C205	B2 C213	A2 C221	D4 C230	A1 C238	A1 C246	C1 C254	C1 C263	D1 C271	D3 C279	C3 C287	B2 CN202	D1 FB201	D3 FB210	D1 FB219	B1 L202	A2 L210	A1 Q201	B1 R205	C2 R214	C3 R222	A1 R230	B1 R242	D2 R253	C2 XL201	A2
C206	B2 C214	A2 C222	D4 C231	A1 C239	A1 C247	C1 C256	C1 C264	D1 C272	C3 C280	C2 C288	A4 CN203	D1 FB202	A1 FB211	D1 IC202	B2 L203	B2 L211	A1 Q202	B1 R206	B2 R215	D3 R223	A1 R231	B4 R243	D1 R256	B1 ZD201	C3
C207	B2 C215	B2 C223	D4 C232	A1 C240	A1 C248	C1 C257	D1 C265	D1 C273	D2 C281	C2 C289	A4 CN204	C2 FB203	A1 FB212	D1 IC202	A4 L204	B2 L212	B1 Q208	B1 R207	B2 R216	D3 R224	A1 R232	C1 R244	D1 R257	B1 ZD202	A1
C208	D3 C216	B2 C224	D4 C233	A1 C241	A1 C249	C1 C258	D1 C266	D1 C274	D2 C282	B1 C290	B4 CN205	B4 FB204	A1 FB213	D1 IC203	D3 L205	B2 L213	B1 Q209	B1 R208	B2 R217	C3 R225	A1 R233	C1 R246	D2 R258	B1 ZD203	A1

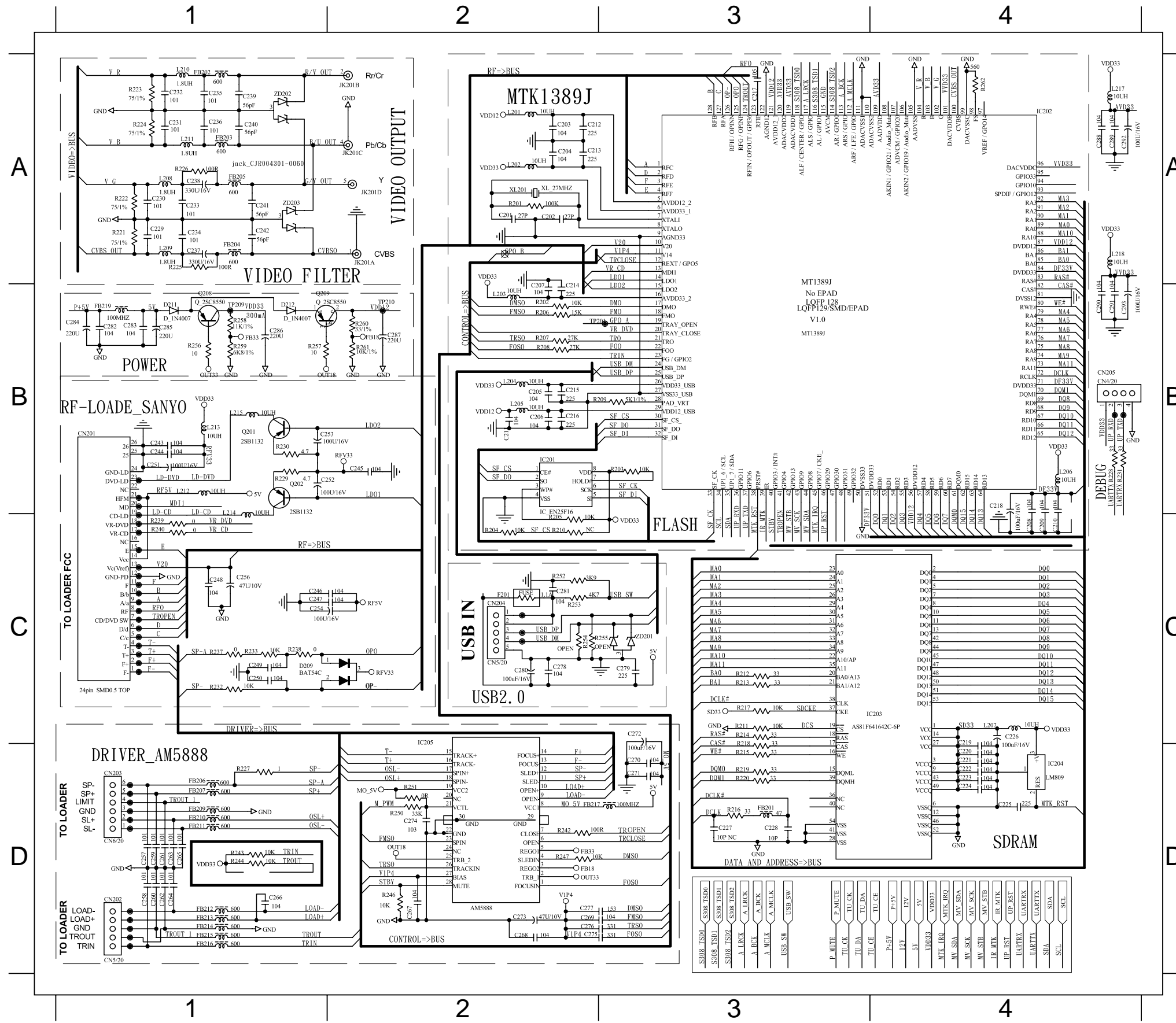

# CIRCUIT DIAGRAM - part three

C301 A1 C309 A2 C317 A1 C325 A2 C333 A4 C341 D1 C349 B3 C357 D3 C365 D3 CN303D4 FB308 D2 IC302 A3 Q301 B3 R303 A3 R311 A1 R319 A2 R327 A3 R337 B1 R350 C3 R358 C3 R366 D4 R374 C4 R385 D1 R393 C4 XL301 C3  
 C302 A2 C310 B3 C318 B3 C326 A2 C334 B1 C342 D1 C350 B3 C358 D3 C366 A1 FB301 A4 FB309 C2 IC303 B4 Q302 C3 R304 A3 R312 A1 R320 A2 R328 A3 R338 B1 R351 C3 R359 C3 R367 D4 R375 C4 R386 D2 R394 D3 ZD301 B3  
 C303 A2 C311 B3 C319 B4 C327 A2 C335 B1 C343 C2 C351 B3 C359 D3 C367 A1 FB302 B1 FB310 C2 IC304 B4 Q303 C4 R305 A1 R313 A1 R321 A3 R329 A4 R339 B1 R352 D4 R360 C4 R368 D4 R376 C4 R387 D2 R395 D3 ZD302 B3  
 C304 A2 C312 B3 C320 A1 C328 A3 C336 C1 C344 C2 C352 A1 C360 D3 C368 C4 FB303 B1 FB311 C2 IC305 D4 Q304 C4 R306 A1 R314 A1 R322 A3 R330 A4 R340 B4 R353 D4 R361 D4 R369 D3 R377 D1 R388 D2 R396 C2 ZD305 C3  
 C305 C2 C313 B4 C321 A1 C329 A3 C337 C1 C345 B3 C353 B3 C361 C3 C369 D3 FB304 C2 FB312 C2 JK301 B1 Q305 C4 R307 A1 R315 A2 R323 A3 R331 C4 R345 B3 R354 D4 R362 D4 R370 D4 R378 D1 R389 C4 R397 D4  
 C306 C2 C314 B4 C322 A1 C330 A3 C338 C1 C346 B3 C354 B3 C362 C3 C372 B3 FB305 D2 FB313 C2 L301 A1 Q306 D4 R308 A1 R316 A2 R324 A3 R332 A4 R346 B3 R355 D4 R363 D4 R371 D4 R379 D1 R390 C4 R398 C2  
 C307 C2 C315 B4 C323 A1 C331 A3 C339 C1 C347 B4 C355 D3 C363 C3 C373 A1 FB306 C2 FB314 C2 L302 D3 Q307 D4 R309 A1 R317 A2 R325 A3 R333 A4 R347 C3 R356 D2 R364 D4 R372 D4 R383 D1 R391 C4 R399 C2  
 C308 C2 C316 B4 C324 A2 C332 A4 C340 C1 C348 B4 C356 D3 C364 C3 CN302B2 FB307 C2 IC301 A2 L303 D3 R302 A1 R310 A1 R318 A2 R326 A3 R336 B1 R348 C3 R357 C3 R365 D4 R373 C4 R384 D1 R392 C4 TU301 D2

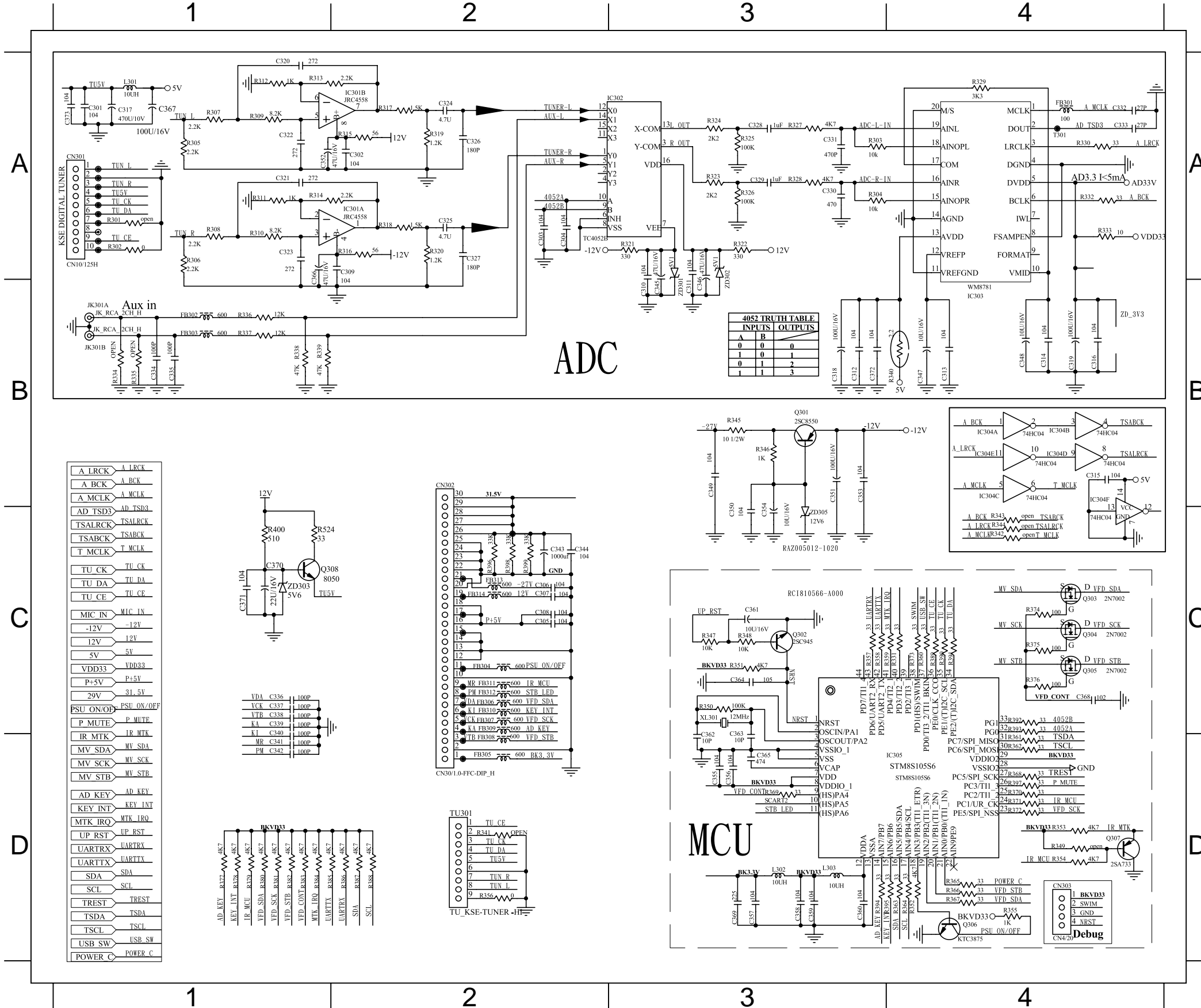



# PCB LAYOUT - TOP VIEW

C201	B1	C237	A1	C277	C2	C319	A2	C353	C5	C415	A3	C447	A3	C471	A4	C501	C4	C544	B4	F201	C2	FB304	C3	IC202	B1	L212	C2	Q302	B2	R215	A2	R239	B2	R308	B1	R333	A2	R361	B2	R390	B3	R417	A3	R440	B3	R486	A4	ZD305	C5
C202	B1	C238	A1	C278	C2	C320	B1	C354	C5	C416	A3	C448	A4	C472	B4	C504	A4	C545	A4	FB201	A2	FB305	C3	IC203	B2	L213	B1	Q303	C3	R216	A2	R240	B1	R309	A1	R336	A2	R362	B2	R391	B3	R418	A3	R441	A3	R487	A4	ZD402	A3
C217	B1	C239	A1	C280	C2	C321	B1	C355	C3	C417	A3	C452	A3	C473	B4	C507	B4	C546	B5	FB202	A1	FB306	C3	IC204	B2	L214	C1	Q304	C3	R218	A2	R242	C2	R310	B1	R337	A2	R363	B3	R392	B2	R419	A3	R443	A5	R488	B4		
C218	B2	C240	A2	C281	C2	C322	A1	C357	C3	C418	A3	C455	B3	C475	C4	C508	A4	C547	B5	FB203	A2	FB307	C3	IC205	C2	L215	C1	Q305	C3	R220	A2	R243	C2	R311	B1	R338	A2	R364	B3	R393	B2	R420	A3	R445	A3	R489	B4		
C219	A2	C247	C2	C283	C3	C323	B1	C360	B3	C419	A3	C456	C4	C476	A4	C513	B4	C548	C5	FB204	A1	FB308	C3	IC301	B1	L301	C1	Q307	B3	R221	A1	R244	C2	R312	A1	R339	A3	R365	B3	R394	B3	R421	B3	R453	A5	R490	B4		
C220	B2	C249	C2	C284	C4	C324	A1	C361	B3	C420	A3	C457	A4	C477	A4	C516	B4	C549	C4	FB205	A1	FB309	C4	IC302	A3	L302	C3	Q402	B3	R222	A1	R247	C2	R313	A1	R340	A2	R366	B3	R395	B3	R422	A3	R455	A3	R491	C4		
C221	B2	C250	C2	C285	C3	C325	A1	C362	C2	C424	B3	C458	A3	C478	A4	C517	C4	C550	C4	FB206	C2	FB310	C4	IC303	A2	L303	B3	Q404	A3	R223	A1	R250	C2	R314	B1	R345	C5	R367	B3	R397	B2	R423	A3	R470	A3	R512	A3		
C222	B2	C251	B1	C286	C2	C326	A1	C363	C3	C425	B3	C459	A4	C479	A4	C522	A4	C551	C5	FB207	C2	FB311	C4	IC304	B2	L401	A5	R201	B1	R224	A2	R251	C2	R315	A1	R346	C5	R368	B2	R403	A3	R424	A3	R472	A3	R513	B3		
C223	A2	C252	B1	C287	C3	C327	A1	C364	B2	C426	A3	C460	B3	C484	B4	C523	B4	CN201	C1	FB210	C2	FB312	C4	IC305	B3	L402	A4	R202	B2	R225	A1	R252	B2	R316	A1	R347	B2	R369	C3	R404	A3	R425	A3	R473	A4	R515	B5		
C225	B2	C253	B1	C292	B1	C328	A2	C366	B1	C427	A3	C461	A3	C485	B4	C524	A4	CN202	C3	FB211	C2	FB313	C5	IC401	A3	L403	B5	R203	B2	R226	A1	R253	C2	R317	A1	R348	B2	R370	B2	R405	A3	R426	B3	R474	B3	R519	B5		
C226	B2	C254	C1	C293	B1	C329	A2	C367	C1	C436	A5	C462	A3	C486	B4	C525	A5	CN203	C3	FB212	C2	FB314	C4	IC403	A4	L404	B5	R204	B2	R227	C2	R256	C3	R318	B1	R350	C3	R371	B3	R408	A3	R427	A3	R475	B4	R520	B5		
C229	A1	C256	C1	C302	A1	C343	C5	C368	C3	C437	C4	C463	B4	C487	B4	C526	A5	CN204	C2	FB213	C2	FB401	C5	IC404	B4	L406	B5	R205	B2	R228	B2	R258	C3	R319	A1	R351	B2	R372	B3	R409	A3	R428	B3	R476	B3	R525	A3		
C230	A1	C266	C2	C306	C5	C345	A2	C369	C3	C440	C5	C464	B3	C492	A4	C527	A5	CN205	B2	FB215	C2	FB402	C5	JK201	A1	L407	B5	R206	C2	R229	B1	R259	C3	R320	B1	R352	B3	R373	B3	R410	A3	R429	B3	R477	B4	TU301	B1		
C231	A2	C269	C2	C309	B1	C346	A2	C402	A3	C441	C4	C465	B3	C493	A4	C528	A5	CN302	C4	FB216	C2	FB403	B5	JK301	A2	L408	B5	R207	B2	R230	B1	R262	B1	R327	A3	R353	B3	R374	C3	R411	A3	R430	B3	R478	C3	XL201	B1		
C232	A1	C272	C3	C314	A3	C347	A3	C403	A3	C442	B4	C466	B4	C494	A4	C529	A5	CN303	B2	FB217	C3	FB404	B4	JK401	A5	Q201	C1	R208	B2	R231	B2	R303	A3	R328	A3	R354	B3	R375	C3	R412	B3	R431	B3	R479	C4	XL301	C3		
C233	A1	C273	C2	C315	A2	C348	A2	C404	A3	C443	B4	C467	B3	C495	B4	C532	B4	D209	C2	FB219	C3	FB405	B5	L208	A1	Q202	B1	R209	B2	R232	C2	R304	A3	R329	A2	R357	B3	R376	C3	R413	A3	R432	B3	R480	A3	XL401	A3		
C234	A1	C274	C2	C316	A2	C349	C5	C405	A3	C444	B4	C468	B3	C498	B4	C533	B5	D211	C3	FB301	A2	FB406	B4	L209	A1	Q208	C3	R212	A2	R233	C2	R305	B1	R330	A2	R358	B3	R379	B3	R414	A3	R434	B3	R481	B3	ZD201	C2		
C235	A1	C275	C2	C317	B1	C351	C5	C412	A3	C445	A4	C469	C4	C499	B4	C542	A4	D212	C3	FB302	A2	FB407	C4	L210	A1	Q209	C3	R213	A2	R237	C2	R306	B1	R331	A3	R359	B3	R383	C3	R415	A3	R438	A3	R484	A3	ZD202	A1		
C236	A2	C276	C2	C318	A2	C352	B1	C414	B3	C446	A5	C470	A4	C500	B4	C543	B4	D408	A3	FB303	A2	IC201	B2	L211	A2	Q301	C5	R214	A2	R238	C2	R307	A1	R332	A3	R360	B3	R389	B3	R416	A3	R439	A3	R485	B3	ZD203	A1		

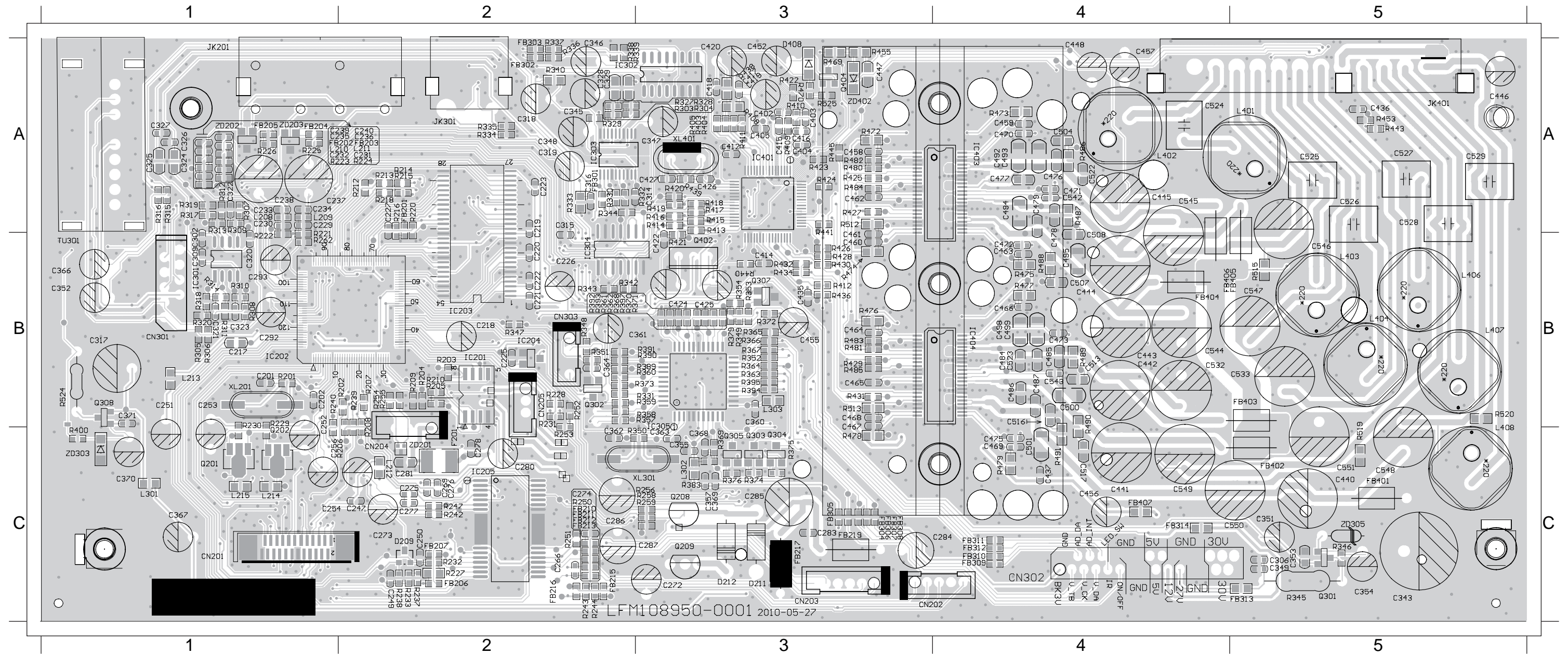

# PCB LAYOUT - BOTTOM VIEW

C203	B1	C213	B1	C245	B1	C264	C3	C290	B1	C312	A2	C338	C4	C365	B3	C413	B3	C439	A4	C488	B5	C509	B5	C534	A4	D407	A5	L204	B2	R219	A2	R325	A3	R388	B3	R437	B3	R457	A5	R468	A5	R502	B5	R514	B4
C204	B1	C214	B2	C246	C1	C265	C3	C291	B1	C313	A3	C339	C4	C372	A3	C421	A3	C449	A5	C489	B5	C510	A5	C535	A4	D409	A3	L205	B2	R246	B2	R326	A3	R396	C5	R442	A5	R458	A5	R471	B3	R503	A5	R516	B4
C205	B2	C215	B2	C248	C1	C267	C2	C301	B1	C330	A2	C340	C4	C373	A1	C428	A3	C450	A4	C490	B5	C511	A5	C536	A5	D411	A3	L206	B2	R257	C3	R355	B3	R398	C5	R444	A4	R459	A5	R492	A4	R504	A5	R517	B4
C206	B2	C216	B2	C257	C3	C268	C2	C303	B3	C331	A2	C341	C4	C401	A3	C429	A3	C451	A4	C491	B5	C512	B5	C537	B5	D412	A5	L207	B2	R260	C3	R356	A1	R399	C5	R446	A4	R460	A5	R494	A5	R505	B5	R518	B4
C207	B2	C224	B2	C258	C4	C270	C2	C304	B3	C332	A2	C342	C4	C406	A3	C430	A3	C454	A5	C496	A5	C514	B5	C538	B5	FB209	C3	L217	B1	R261	C3	R377	B3	R401	A3	R449	A5	R462	A4	R495	B5	R506	B5	R521	C5
C208	B2	C228	A2	C259	C3	C271	C3	C305	C4	C333	A2	C344	C4	C407	B3	C431	A3	C474	B4	C497	B5	C515	B5	C541	A5	FB214	C4	L218	B1	R302	B1	R378	B3	R402	A3	R450	A5	R463	A4	R496	A5	R507	B5	R522	B4
C209	B2	C241	A1	C260	C3	C279	C2	C307	C4	C334	A2	C350	C5	C408	B3	C432	A3	C480	A5	C502	B5	C518	A5	D401	A5	IC402	A5	Q306	B3	R321	A2	R384	B3	R406	A3	R451	A4	R464	A5	R498	B5	R508	A5	R523	B5
C210	B2	C242	A2	C261	C4	C282	C4	C308	C4	C335	A2	C356	B3	C409	A3	C433	A3	C481	A5	C503	A5	C519	A5	D402	A5	L201	B1	Q401	A3	R322	A2	R385	B3	R407	A3	R452	A5	R465	A5	R499	A5	R509	A5	ZD301	A2
C211	B2	C243	C2	C262	C4	C288	B1	C310	A2	C336	C4	C358	B3	C410	A3	C434	A3	C482	B5	C505	A4	C520	B5	D403	A5	L202	B1	R211	A2	R323	A3	R386	B3	R433	A4	R454	A2	R466	A5	R500	A4	R510	B5	ZD302	A2
C212	B1	C244	B1	C263	C3	C289	B1	C311	A2	C337	C4	C359	B3	C411	A3	C438	C5	C483	B5	C506	A4	C521	C5	D404	A5	L203	B1	R217	A2	R324	A3	R387	B3	R435	A2	R456	A5	R467	A5	R501	A4	R511	C5	ZD401	B3

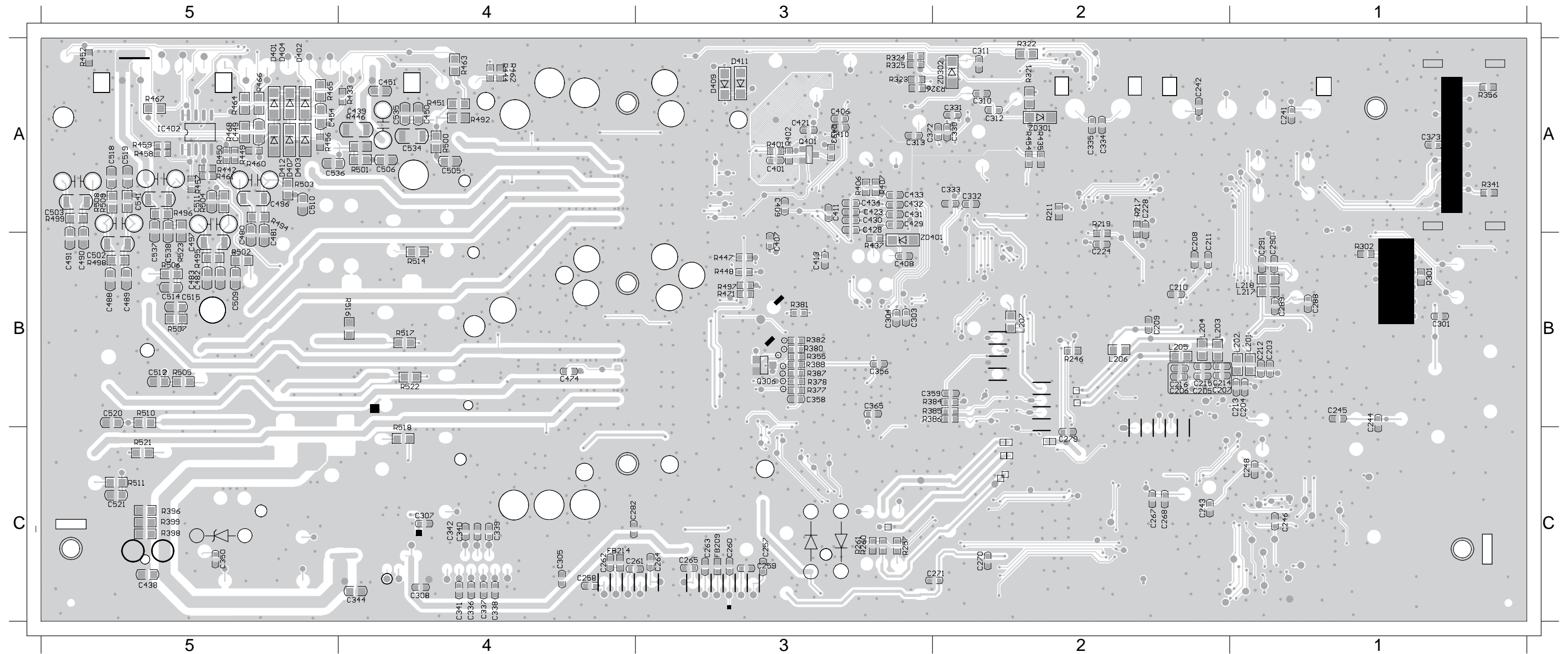

---

# POWER BOARD

---

TABLE OF CONTENTS

Internal IC Diagram .....	8-1
Circuit Diagram .....	8-2
PCB Layout Top View .....	8-3
PCB Layout Bottom View .....	8-4

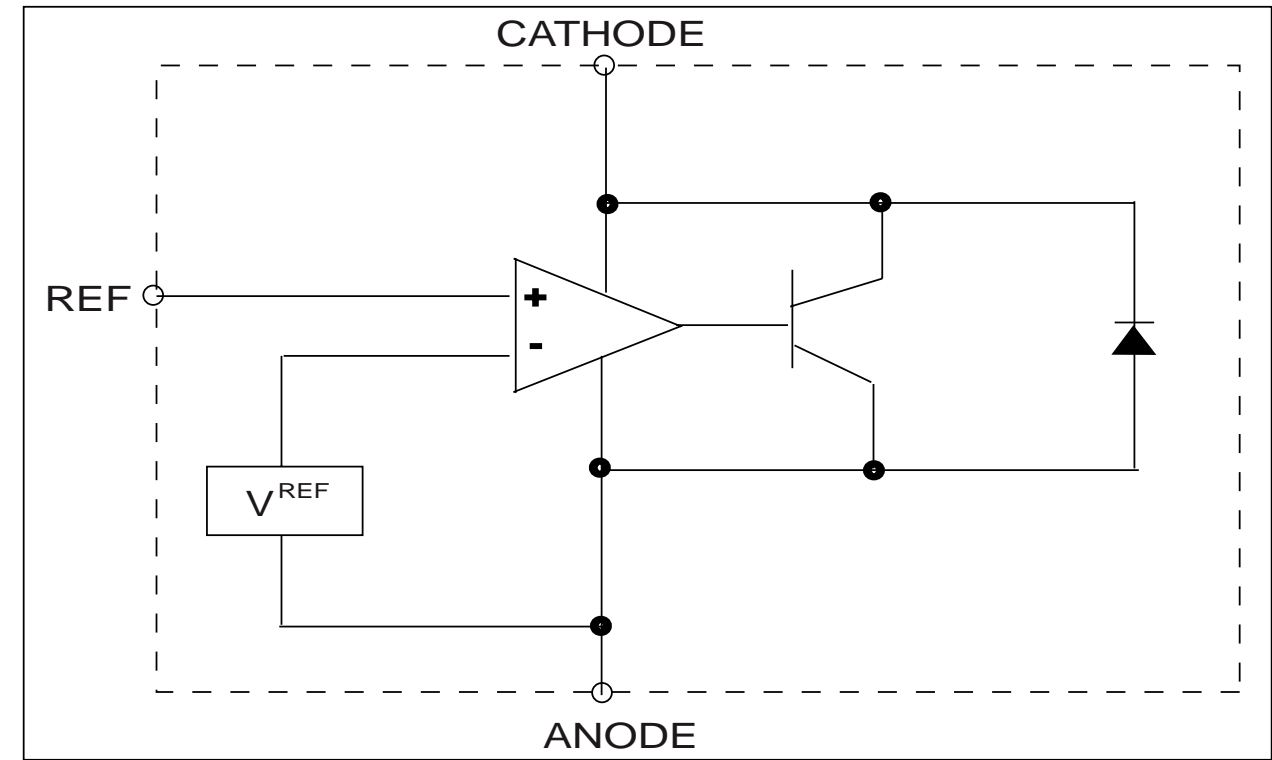

# CIRCUIT DIAGRAM

BD901 A1 C907 A1 C916 C2 C930 B2 C938 B4 C944 A3 C950 A3 C961 C3 C968 A4 D903 B2 D909 B2 IC901 B1 L902 A3 Q903 B2 R902 C1 R911 B1 R917 B2 R923 A3 R929 A2 R936 A3 R942 A3 R960 B1 T901 A2 ZD904 A2  
 C902 B1 C910 A1 C917 B1 C932 A3 C939 A3 C945 A3 C951 A3 C962 A1 CN901 C1 D904 A3 D910 B2 IC902 C2 L903 A3 Q904 B2 R903 C1 R912 B2 R918 B2 R924 A3 R930 A2 R937 A3 R943 C4 R961 C1  
 C903 C1 C912 A1 C922 A3 C933 A3 C940 B4 C946 A3 C952 A4 C963 C4 CN902 B4 D905 A2 D911 C2 IC903 C3 L904 A3 Q905 A3 R904 B1 R913 B2 R919 B2 R925 A3 R932 C3 R938 C3 R944 C4 R962 B2 ZD901 C1  
 C904 B1 C913 C2 C925 A3 C934 C3 C941 B4 C947 B4 C953 A3 C964 A1 CN903 A4 D906 A3 D912 C3 IC904 C3 L905 A3 Q906 C3 R905 B1 R914 B2 R920 B2 R926 A3 R933 A4 R939 C3 R945 A4 R963 B2 ZD901 C1  
 C905 B1 C914 C2 C926 A4 C935 C3 C942 A3 C948 B4 C954 A3 C966 A1 D901 A1 D907 A2 F901 C1 IC904 B4 NTC901 C1 Q907 C3 R906 B1 R915 C2 R921 A1 R927 B2 R934 B2 R940 A3 R946 A4 R964 C4 ZD902 B2  
 C906 B1 C915 C2 C929 A3 C936 C3 C943 B2 C949 A3 C956 A3 C967 A1 D902 A3 D908 A3 GT902 B1 L901 B1 Q901 A2 R901 C1 R908 A1 R916 C2 R922 B2 R928 A3 R935 C3 R941 C3 R947 A4 T901 A2 ZD903 A4

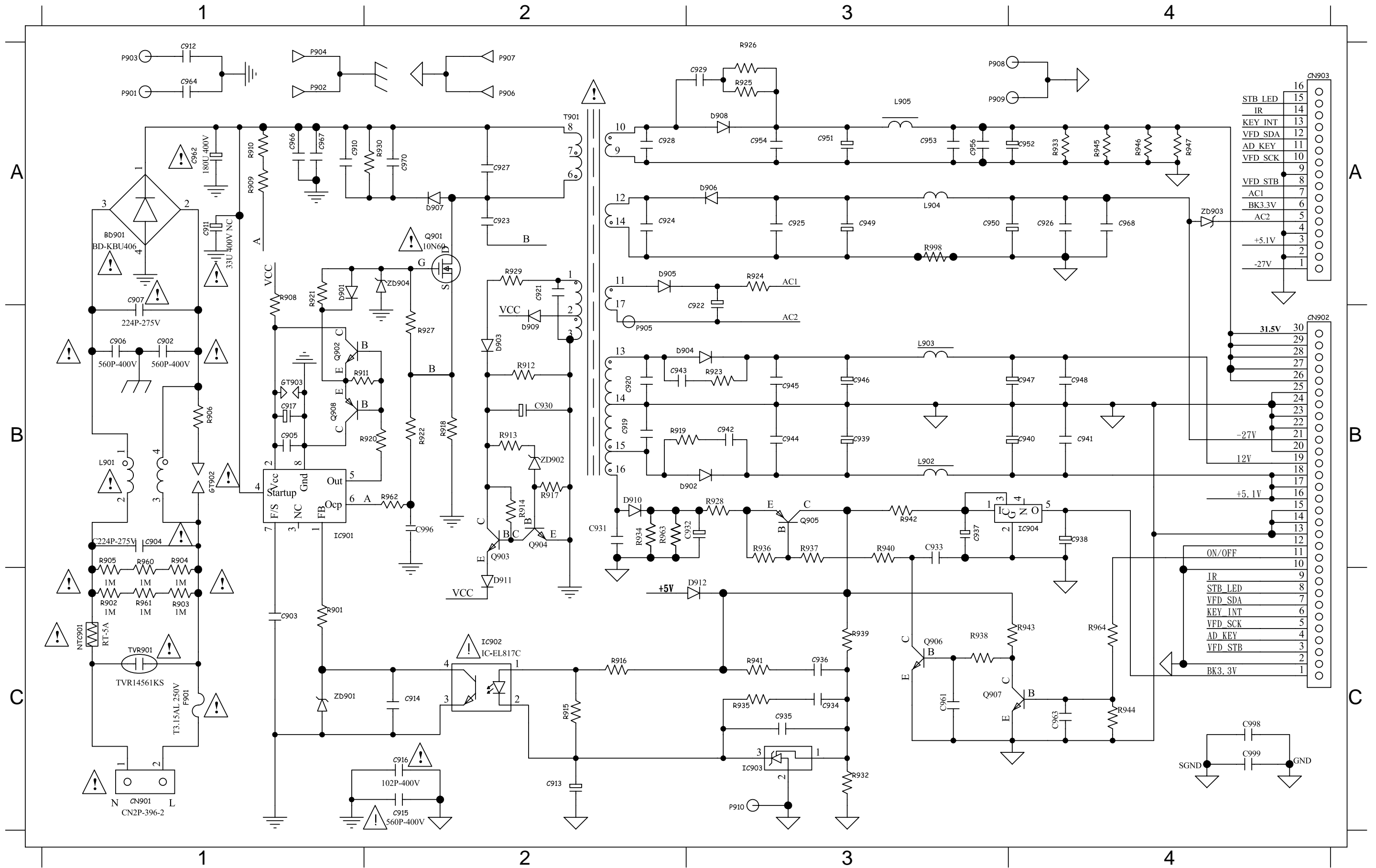

STB LED	16
IR	15
KEY INT	14
VFD_SDA	13
VFD_SCK	12
AD KEY	11
VFD STB	10
VFD STB	9
AC1	8
BK3.3V	7
AC2	6
+5.1V	5
-27V	4
	3
	2
	1

31.5V	30
	29
	28
	27
	26
	25
	24
	23
	22
-27V	21
12V	20
	19
	18
+5.1V	17
	16
	15
	14
	13
	12
ON/OFF	11
IR	10
STB LED	9
VFD_SDA	8
VFD_SCK	7
KEY INT	6
VFD STB	5
AD KEY	4
VFD STB	3
BK3.3V	2
	1

# PCB LAYOUT - TOP VIEW

BD901	B1	C910	A2	C917	B3	C938	C4	C950	D3	CN901	D1	D905	C3	D912	C4	J902	B2	J908	C4	J915	D3	L904	D2	Q905	C4	R924	D4
C902	B1	C912	A1	C922	D2	C939	C4	C951	D2	CN902	D4	D906	C3	F901	D2	J903	A3	J909	C4	J916	D3	L905	D3	R906	B1	R930	A2
C903	A3	C913	C3	C930	B4	C940	D4	C952	D3	CN903	A4	D907	A3	GT902	C2	J904	A3	J910	D4	J917	D3	NTC901	D1	R912	B4	T901	C2
C904	D1	C914	B3	C932	C4	C946	C3	C962	B1	D902	C3	D908	D2	IC903	B4	J905	A4	J912	D4	L901	C2	Q901	A2	R914	B4	T901	C2
C906	C1	C915	B2	C933	D4	C947	D3	C966	A2	D903	B4	D909	B4	IC903	B4	J906	A4	J913	D4	L902	C3	Q903	B4	R918	A2	TVR901	D1
C907	B1	C916	B3	C935	C4	C949	D2	C967	B2	D904	C3	D910	C3	J901	B1	J907	B3	J914	D4	L903	D3	Q904	A4	R923	C3		

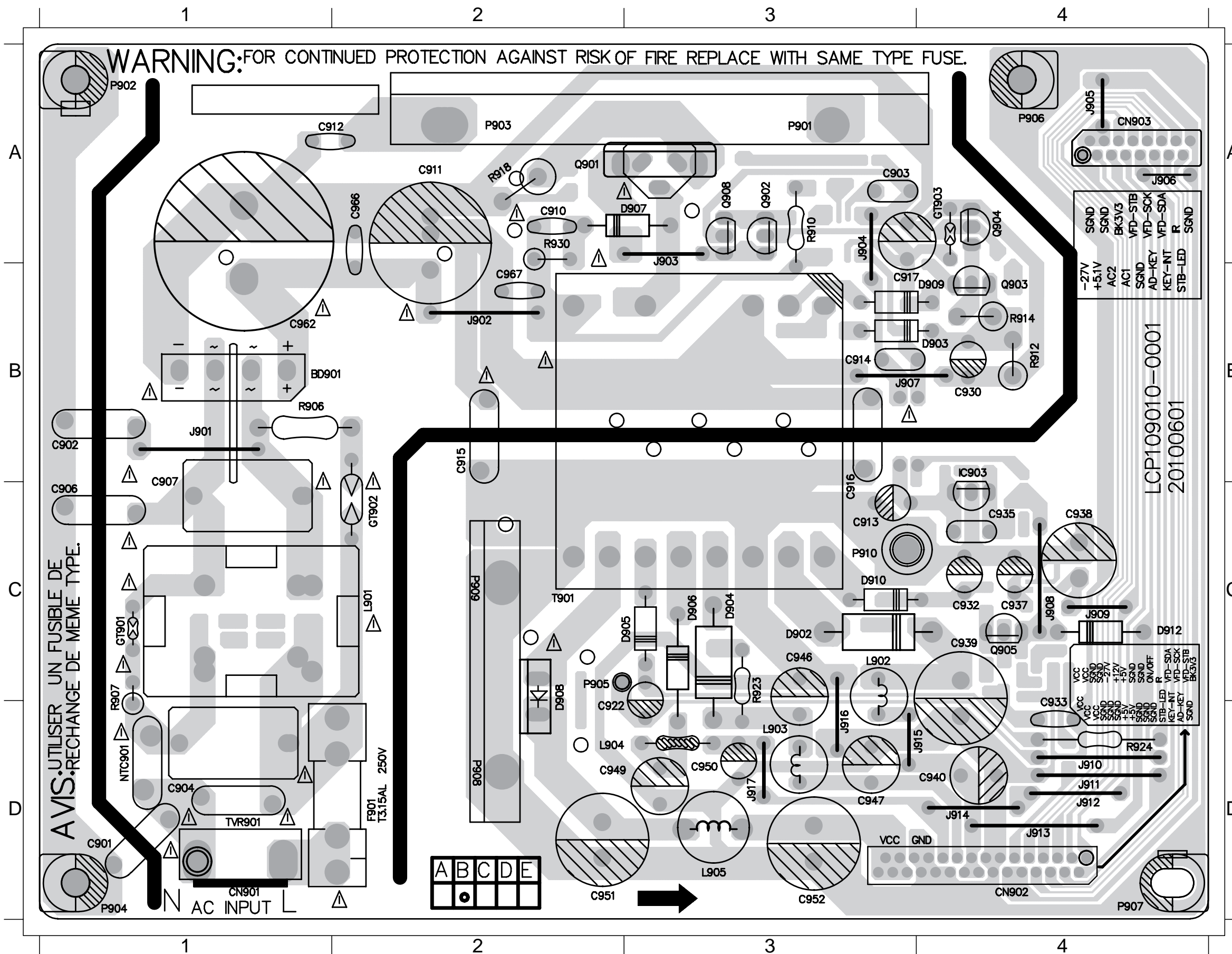

# PCB LAYOUT - BOTTOM VIEW

8 - 4

8 - 4

C905	A3	C936	C4	C945	D3	C961	D4	D911	B4	Q907	C4	R905	C1	R916	B4	R922	A3	R929	B3	R936	C4	R941	C4	R946	D3	R963	C3	ZD903	A4
C925	D3	C941	D4	C948	D3	C963	C4	IC901	B3	R901	B3	R908	B3	R917	A4	R925	D2	R932	C4	R937	C4	R942	C4	R947	D3	R964	D4	ZD904	A2
C926	D4	C942	C3	C953	D3	C964	A3	IC902	B4	R902	C1	R911	B3	R919	C3	R926	D2	R933	D3	R938	C4	R943	C4	R960	C1	ZD901	B4		
C929	C2	C943	C3	C954	D3	C968	D4	IC904	C4	R903	C1	R913	B4	R920	A3	R927	A2	R934	C3	R939	C4	R944	C4	R961	C1	ZD901	B4		
C934	B4	C944	C3	C956	D3	D901	A3	Q906	D4	R904	C1	R915	C3	R921	A2	R928	C4	R935	B4	R940	D4	R945	D3	R962	A3	ZD902	A4		

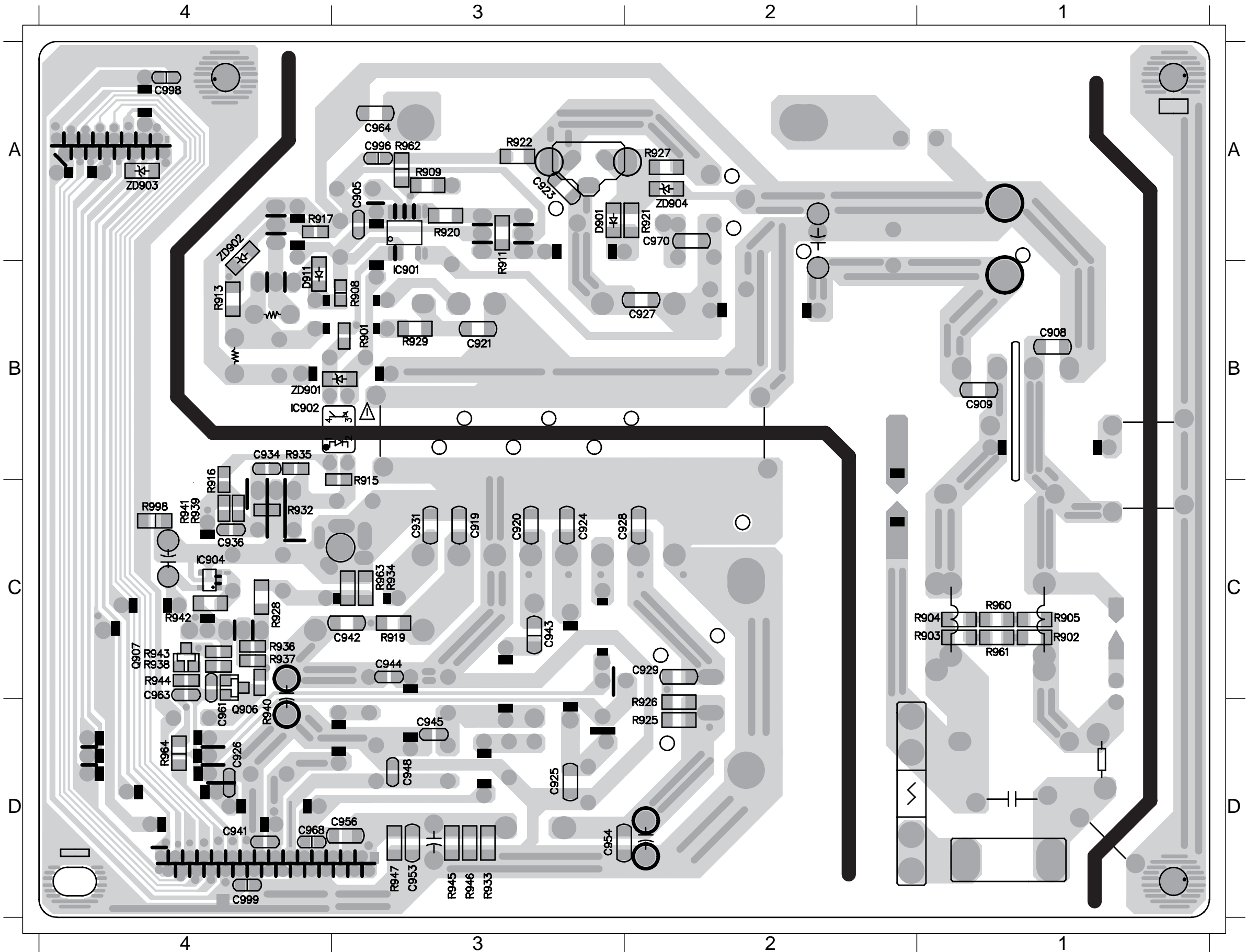

Mechanical Exploded View

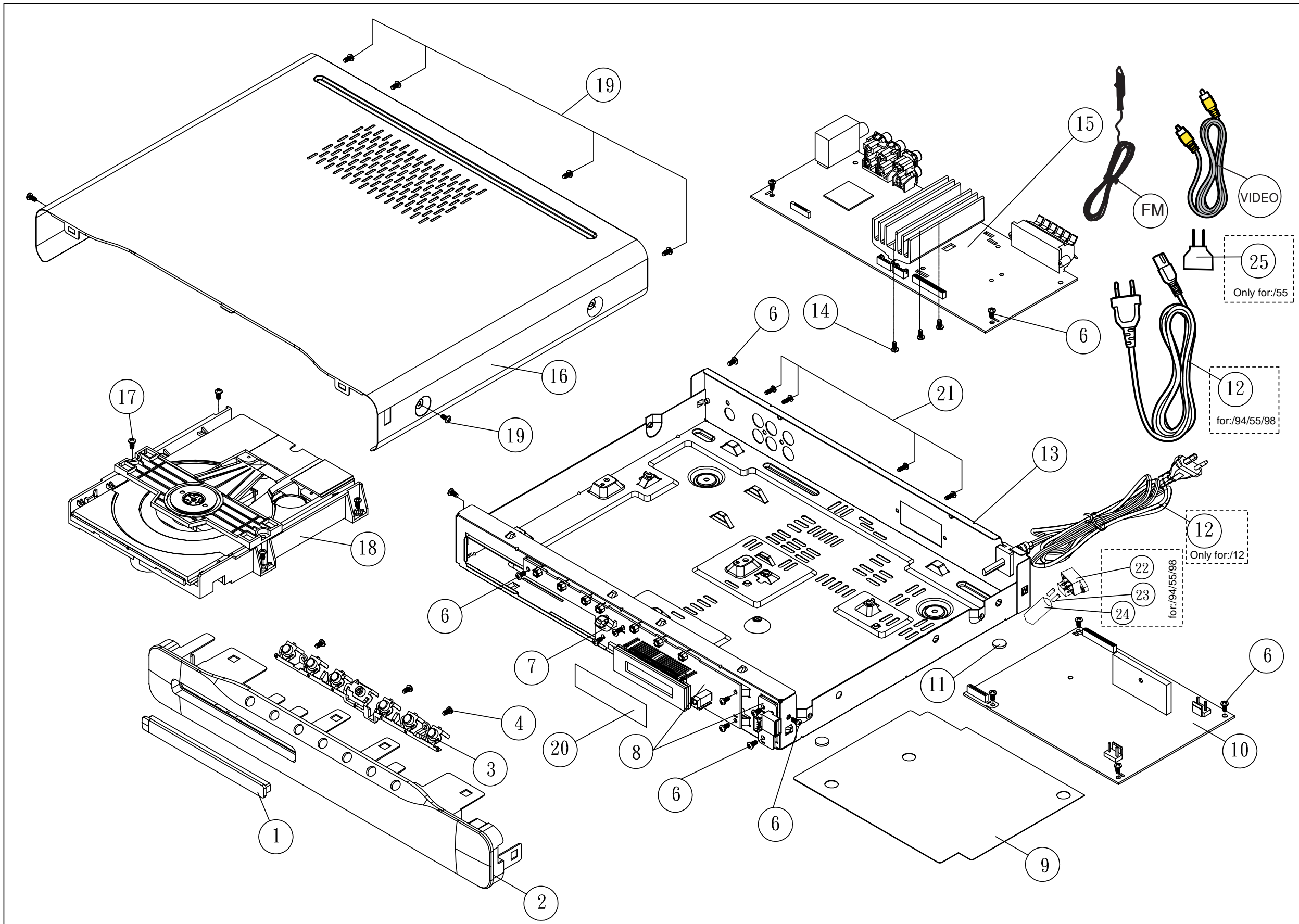

4	HSP140054-1060	SCREW T3.0x1.06PxL6mm NICKEL	17	HST143084-1080	SCREW M3.0x0.5PxL8mm NICKEL
6	HST143084-1060	SCREW M3.0x0.5PxL6mm NICKEL	19	HST143084-3060	SCREW M3x0.5PxL6mm BLACK OXIDE
14	HSP140054-1100	SCREW T3.0x1.06PxL10mm NICKEL	21	HSP140054-1080	SCREW T3.0x1.06PxL8mm NICKEL

# REVISION LIST

Version 1.0

\*Initial release

Version 1.1

\*Update to include /98 version.